

ARMOURCOAT®

SUSTAINABLE LUXURY FINISHES

TECHNICAL DOCUMENT

# ACOUSTIC



# CONTENTS

---

<b>1. PRODUCT DESCRIPTION</b>	<b>3</b>
-------------------------------	----------

---

<b>2. TEST DATA</b>	<b>4</b>
2.1. FIRE TESTING	4
2.2. VOLATILE ORGANIC COMPOUND (VOC) TESTING	4
2.4. ENVIRONMENTS BUILDING CERTIFICATION	5
2.5. LEED CONTRIBUTION	6
2.6. ACOUSTIC PERFORMANCE	6
2.7. MOULD/MILDEW RESISTANCE	7
2.8. ENVIRONMENTAL PRODUCT DECLARATION (EPD)	7
2.9. LIVING BUILDING CHALLENGE (LBC)	7

---

<b>3. SUITABLE SUBSTRATES</b>	<b>8</b>
3.1. SYSTEM BUILD-UP	8
3.2. SUBSTRATE PREPARATION	9
3.3. CONSTRUCTION OF A SUSPENDED CEILING (BS EN 13964)	10
3.4. CONCRETE SUBSTRATE	10
3.5. EXISTING PLASTERED/DECORATED SURFACE	10
3.6. CURVED AND DOMED SURFACES	10
3.7. FITTINGS	11
3.8. TAPE	12
3.9. DETAILING	13
3.10. SITE REQUIREMENTS	14
3.11. INSTALLATION PROCESS TIMELINE	14
3.12. OPTIONAL SURFACE PROTECTION	15
3.13. DIAGRAMS	15

---

<b>4. CLEANING AND MAINTENANCE</b>	<b>26</b>
4.1. DUST REMOVAL	26
4.2. STAIN REMOVAL	26
4.3. SCUFF AND SURFACE MARKS	26
4.4. DAMAGE REPAIR	26
4.5. RESTORATION	26

---

<b>5. WARRANTY</b>	<b>26</b>
--------------------	-----------

# ACOUSTIC

---

## 1. PRODUCT DESCRIPTION

Armourcoat Acoustic offers the appearance of a consistent smooth seamless marble plaster surface combined with exceptional sound absorption and acoustic performance.

Armourcoat have used their considerable expertise in the formulation of marble based plaster finishes to create an elegant plaster finish that appears smooth and even but still allows sound waves and energy to pass through the surface so they can be absorbed and attenuated in the layer of mineral wool beneath the surface.

The system comprises of a special mineral wool composite panel pre coated with the system Basecoat. The panels are bonded onto the substrate using Armourcoat Bondplast and then finished with a seamless layer of the Armourcoat Acoustic plaster.

Armourcoat Acoustic can be pigmented to a wide range of colours and is suitable for application to both flat and curved surfaces.

Armourcoat Acoustic system is created using Armourcoat Bondplast Adhesive, Armourcoat Acoustic factory coated Mineral Wood Boards, Armourcoat Acoustic Filler and Armourcoat Acoustic Topcoat AP335 (as standard). This Document will refer to this system as Armourcoat Acoustic.

### Properties

- Natural mineral system
- Mineral wool panels with 80% post-consumer recycled content
- Acoustic Basecoat made from expanded glass foam granules with 72% recycled content
- Acoustic Topcoat plaster made from up to 93% recycled material
- Average System recycle content of 73%
- No Measurable VOC's
- Factory prepared panels for immediate installation
- Seamless finish with exceptional acoustic management performance
- 28mm and 48mm systems for Class A and B performance
- Resistant to mould and mildew
- Up to 200m<sup>2</sup> without joint
- A2 Fire classification
- Ultra matt surface
- Durable marble plaster finish
- Wide range of colours available
- Environmental Product Declaration
- Health Product Declaration
- LBC Red List Compliant

## 2. TEST DATA

Polished Plaster has been subjected to a wide range of Fire, VOC, durability, and other performance testing.

### 2.1. FIRE TESTING

#### 2.1.1. European Fire Test Results

Independent tests were carried out in the UK for classification of reaction to fire performance in accordance with EN13501-1:2007.

REACTION TO FIRE CLASSIFICATION
A2 - s1, d0

#### 2.1.2. American Fire Test Results

Test carried out in accordance with ASTM E84 - 20, Standard Test Method for Surface Burning Characteristics of Building Materials.

##### 28mm System

TEST TYPE	RESULT
Flame Spread Index	15
Smoke Development Index	5
Flame Spread Classification	A

##### 48mm System

TEST TYPE	RESULT
Flame Spread Index	15
Smoke Development Index	10
Flame Spread Classification	A

### 2.2. VOLATILE ORGANIC COMPOUND (VOC) TESTING

#### 2.2.1. VOC Content Testing

A sample of Armourcoat Acoustic was tested by an accredited European laboratory (Eurofins) to ASTM D2369, Standard Practise for Determining Volatile Organic Compound (VOC) Content of Paints and Related Coatings.

##### Test Result

TEST METHOD	VOC (G/L)	VOC (LBS/GAL)	LIMIT OF DETECTION (G/L)
ISO 11890-2	<1.0	<1.0	1

### 2.2.2. VOC Emissions Testing

A sample of Armourcoat Acoustic was tested by Eurofins to a wide range of emissions standards including EN 16516, ISO 16000-6, AgBB and French and Belgian VOC regulations.

#### Evaluation of results

REGULATION OR PROTOCOL	CONCLUSION	VERSION OF REGULATION OR PROTOCOL
French VOC Regulation	A+	Decree of March 2011 (DEVL1101903D) and Arrêté of April 2011 (DEVL1104875A) modified in February 2012 (DEVL1133129A)
French CMR Components	Pass	Regulation of April and May 2009 (DEVP0908633A and DEVP0910046A)
Italian CAM Edilizia	Pass	Decree 11 October 2017 (GU n.259 del 6-11-2017)
ABG/AgBB	Pass	Ausschuss zur gesundheitlichen Bewertung von Bauprodukten (June 2021)
Belgian Regulation	Pass	Royal decree of May 2014 (C-2014/24239)
Indoor Air Comfort®	Pass	Indoor Air Comfort 7.0 of May 2020
BREEAM International	Exemplary Level	BREEAM International New Construction v2.0 (2016)
LEED v4.1 BETA	Pass	February 2021
CDPH	Pass	CDPH/EHLB/Standard Method V1.2. (January 2017)

A sample of Armourcoat Acoustic Plaster System was tested for indoor air quality following the requirements of CDPH/EHLB/Standard Method by an accredited American laboratory.

ENVIRONMENT	PRODUCT USAGE	PRODUCT SURFACE AREA	ROOM VOLUME	VENTILATION RATE (ACH)	PRODUCT COMPLIANCE
Classroom	Ceiling	89.2 m <sup>2</sup>	231 m <sup>3</sup>	0.82	Yes
Office	Ceiling	11.1 m <sup>2</sup>	30.6 m <sup>3</sup>	0.68	Yes

### 2.4. ENVIRONMENTS BUILDING CERTIFICATION

BREEAM International – Exemplary status for VOC Emissions

CDPH - CDPH/EHLB/Standard Method V1.2. (January 2017)

Full Certificates supplied on Request.



## 2.5. LEED CONTRIBUTION

Contribution statement: Armourcoat Acoustic Plaster System qualifies for points under the LEED Green Building Rating System.

LEED is a set of performance standards based on existing and proven technology to evaluate environmental performance from a whole building perspective over the building's lifecycle. They provide a definitive standard for what constitutes a green building in design, construction and operation.

LEED guidelines vary from one program to another. Categories may change. Consultation with the Green Building Certification Institute is recommended.

### **EA Credit 1 - Optimise Energy Performance**

Armourcoat Acoustic high density mineral wool panels provide additional thermal insulation which reduces energy use for optimised energy performance.

### **MR Credit 4 - Recycled Content**

Armourcoat Acoustic consists of up to 74% recycled content including post-consumer and pre consumer recycled material.

### **IEQ Credit 4 - Low Emitting Materials**

Armourcoat Acoustic has no harmful volatile organic compounds.

### **IEQ Credit 7.1 - Thermal Comfort, Design**

Armourcoat Acoustic high density mineral wool panels provide an excellent source of thermal insulation, reducing energy use and providing improved thermal comfort.

### **EQ Credit 9 - Enhanced Acoustical Performance**

Armourcoat Acoustic has been professionally and independently tested proving it will effectively absorb and dispel sound energy thus decreasing echo and reverberation, providing a much improved sound quality environment.

**Please see LEED STATEMENT for further details.**

## 2.6. ACOUSTIC PERFORMANCE

Independent tests were carried out in the UK on the Armourcoat Acoustic® Plaster System to determine the Sound Absorption Coefficient ( $\alpha_s$ ), conducted in accordance with European Standard EN ISO 354. Single figure ratings of sound absorption performance, known as the Weighted Sound Absorption Coefficient ( $\alpha_w$ ), Sound Absorption Class, Sound Absorption Average (SAA) and Noise Reduction Coefficient (NRC) are derived from these measurements in accordance with European Standard EN ISO 11654 and American Standard ASTM C423-17. Tests were carried out by the AIRO Acoustics Laboratory, a UKAS accredited testing laboratory No. 0483, on 18th December 2019 and 22nd April 2020. The Armourcoat Acoustic® Plaster System achieved BS EN ISO 354:2003 Weighted Sound Absorption Coefficient ( $\alpha_w$ ) of 0.80, class B (28mm system) to 0.95, class A (48mm system).

THICKNESS	EN ISO 354:2003	CLASS	ASTM C423-17	NOISE REDUCTION COEFFICIENT (NRC)
	WEIGHTED SOUND ABSORPTION COEFFICIENT ( $\alpha_w$ )		SOUND ABSORPTION AVERAGE (SAA)	
28mm	0.80	B	0.82	0.85
48mm	0.95	A	0.92	0.95

## 2.7. MOULD/MILDEW RESISTANCE

ASTM D 3273-16 Standard Test Method for Resistance to Growth of Mould on the Surface of Interior Coatings in an Environmental Chamber.

PLASTER	FINISH	POST TREATMENT	WEEK 1	WEEK 4
Armourcoat Acoustic	AP335	-	10/10/10	10/10/10

\*Rating system: 1 is very poor. 10 is no growth.

Testing was carried out by an accredited American testing laboratory.

## 2.8. ENVIRONMENTAL PRODUCT DECLARATION (EPD)

In accordance with ISO 14025, ISO 21930 and EN 15804 - The International EPD® System. Core environmental impact indicator EN 15804 +A2 PEF (All categories Cradle to grave).

### 28mm System

Global Warming Potential (GWP) 0.442 kg CO<sub>2</sub>e

Coverage rate 9.75-10.25 kg/m<sup>2</sup>

GWP per m<sup>2</sup> 4.42 kg CO<sub>2</sub>e / m<sup>2</sup>

### 48mm System

Global Warming Potential (GWP) 0.520 kg CO<sub>2</sub>e

Coverage rate 12.75-13.25 kg/m<sup>2</sup>

GWP per m<sup>2</sup> 6.76 kg CO<sub>2</sub>e / m<sup>2</sup>

## 2.9. LIVING BUILDING CHALLENGE (LBC)

Living Building Challenge (LBC) Red List Approved is a status indicating that a product is in compliance with the requirements of the LBC Challenge. Armourcoat Acoustic System has met this challenge and contains no materials that appear on the LBC Red List - March 2022.

### 3. SUITABLE SUBSTRATES

Armourcoat Acoustic Mineral Wool Boards can easily be cut with a handsaw or cutting blade. They are adhered to the substrate using Armourcoat Bondplast. Mix the Armourcoat Bondplast to a workable consistency and apply to the back of the panels using a 6mm notched trowel. Adhere panels to the substrate in an offset block pattern making sure each panel is tightly butted up to the adjoining panels.

The Armourcoat Acoustic Mineral Wool Boards can be applied over a wide range of substrates including:

- Plasterboard onto suspended frame
- GRG
- Cement board
- Direct to concrete
- Existing plastered surfaces
- Previously decorated surfaces

The Armourcoat Acoustic is not suitable for application to wooden or MDF substrates or surfaces which are weak and crumbling or have flaking or peeling paint or plaster.

For old ceilings that have been previously treated with a lining paper or wallpaper it is essential to test the adhesion and treat the surface with a sealer/primer to stop the moisture from the Armourcoat Bondplast softening the adhesion of the paper.

If in doubt conduct 3 no. 100mm x 100mm pull off test to check the levels of adhesion before applying the system. (If the 100mm x 100mm can suspend a 1kg weight you have a safety factor of 12 or 1200%).

#### 3.1. SYSTEM BUILD-UP

The Armourcoat Acoustic comprises of a special mineral wool panel pre-coated with a porous mineral basecoat (Armourcoat Acoustic Basecoat) and calibrated to an exact thickness.

This board is adhered to the substrate with a gypsum adhesive (Armourcoat Bondplast) and any minor discrepancies between panels is sanded out. The joints/seams are then filled with joint filling compound (Armourcoat Acoustic Filler) that is essentially the same composition as the basecoat that has been factory applied to the boards.

Once dry the entire surface is sanded to a flat smooth surface. The Armourcoat Acoustic Topcoat plaster is then applied to the surface to create a continuous seamless surface.

For surfaces with complex shapes or surfaces subject to very critical cross lighting we would recommend the application of a base layer of AP347 followed by a finishing layer of AP335 or AP347 depending upon the surface texture required.

The first layer must be allowed to dry fully before the application of the final layer.



### 3.2. SUBSTRATE PREPARATION

The Armourcoat Acoustic Plaster System can be applied to a wide range of substrates which should be firm and true and will not move or crack. The most common substrate for the system is plasterboard suspended on a metal frame system.

All joints should be taped with a reinforcing mesh and the joints filled flush with the surface. Skimcoat plaster or jointing compound must be fully dry. Substrates to receive the system directly must be flat and true, devoid of undulation and with all fixtures and fittings already installed by others.

The Armourcoat Acoustic panels are cut and shaped in order to accurately include and house all fixtures and fittings.

Armourcoat or its partners will check substrate quality and suitability with the contractor prior to any system installation. In the event of concerns Armourcoat or its partners will advise on any amendments required. Armourcoat takes no responsibility for substrate build and suitability for installation. Works should not commence until all necessary rectifications have been made and no further adjustments will be made to the location of lights, sprinkler heads etc. All fixtures and fittings must be installed to the necessary depth relative to the thickness of the system panels. Such detailing to be discussed at pre-order meetings between Armourcoat or its partners and the specifier/contractor.

Substrates must be solid and airtight to ensure that air only enters the system without passing through the acoustic layer into the ceiling void. Any gaps between fixtures and fittings set into the substrate must be sealed at the substrate point to prevent air movement. Vents can be introduced to allow for pressure equalisation between the ceiling void and the room or space being treated with the Armourcoat Acoustic Plaster System if required.

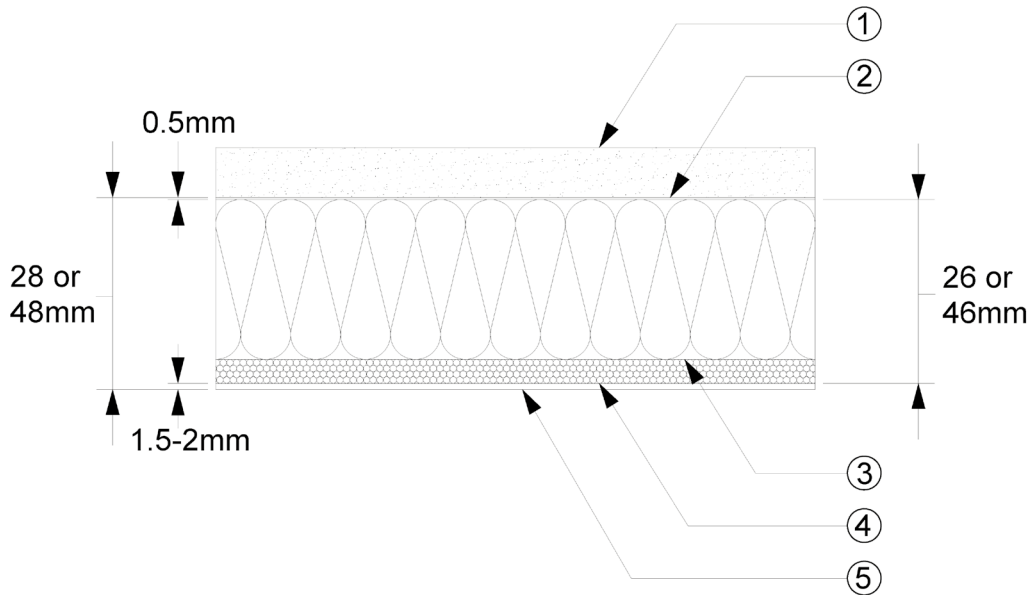

- 1 Plasterboard Substrate
- 2 Armourcoat Bondplast (0.5mm)
- 3 Mineral Wool Panel (20/40mm)
- 4 Armourcoat Acoustic Board Coating (6mm)
- 5 Armourcoat Acoustic Topcoat (2mm)

### 3.3. CONSTRUCTION OF A SUSPENDED CEILING (BS EN 13964)

Armourcoat Acoustic will conform to BS EN 13964 for suspended ceilings provided it is constructed in accordance with the following:

- Ceiling grid system will be constructed from metal frame hanger system designed to accommodate a minimum hanging load of 20kg/m<sup>2</sup>.
- One layer of 12.5mm plasterboard to be fixed to metal frame grid with screw centres of 300mm maximum.
- Plasterboard to be taped and jointed to leave a flush flat surface. The Armourcoat Acoustic Mineral Wool Boards (21mm/41mm) to be bonded onto the plasterboard with Armourcoat Bondplast adhesive.

A standard metal frame ceiling with supports at 450mm intervals and 1 layer of 12.5mm plasterboard is typically rated to 30kg/m<sup>2</sup>.

### 3.4. CONCRETE SUBSTRATE

Ensure that the concrete surface is fully dry and free of any dust or contaminants. Ensure that the concrete surface is sufficiently flat and true and does not have surface discrepancies greater than 3mm.

### 3.5. EXISTING PLASTERED/DECORATED SURFACE

For existing ceilings check that the surface is sound and flat and that any paint or existing decoration is well adhered to the surface.

For old ceilings that have been previously treated with a lining paper or wallpaper it is essential to test the adhesion and treat the surface with a sealer/ primer to stop the moisture from the Armourcoat Bondplast softening the adhesion of the paper.

If in doubt conduct 3 no 100mm x 100mm pull off test to check the levels of adhesion before applying the system. (If the 100mm x 100mm can suspend a 1kg weight you have a safety factor of 12 or 1200%).

### 3.6. CURVED AND DOMED SURFACES

The Armourcoat Acoustic can be used on both single curved and double curved surfaces.

The 48mm system is suitable for curves of down to a 3 metre radius without any modification. For tighter radius curves the mineral wool on the rear of the boards can be cut with parallel slots to increase the boards curvature. The 28mm system is suitable for curves down to a 1 metre radius.

For curved or domed surfaces subject to critical lighting it is important to take great care with the sanding process and it is advisable to apply a coat of AP347 over the entire surface and leave this to dry fully before applying the final finish coat.

There will be an additional cost for curved and double curved surfaces which will depend upon the complexity of each particular project.

## 3.7. FITTINGS

### 3.7.1. Pattresses

Armourcoat Acoustic Pattresses are designed to provide a stable base platform for the fixing of recessed or surface mounted light fittings, recessed speakers, cameras and alarms etc. They are fabricated from a 10mm thick fibre reinforced gypsum (Fermacell) which is pre-coated with the Armourcoat Acoustic Basecoat to the same thickness as the Armourcoat Acoustic Base Boards.

The pattresses have a 30mm wide perimeter that is manufactured from a resin modified glass reinforced gypsum and is bonded onto the board face with Armourcoat Bondplast. The pattresses are fixed into position with screws and Bondplast.

### 3.7.2. Dimensions

Armourcoat Acoustic Pattresses are available in the following standard sizes:

200 x 200mm x 27mm

200 x 200mm x 47mm

300 x 300mm x 27mm

300 x 300mm x 47mm

### 3.7.3. Custom Sizes

There are many situations where either larger or longer pattresses are required. Armourcoat offers a fibre reinforced gypsum panel which has been pre-coated with the Acoustic basecoat to cater for such requirements. Dimensions are 1200mm x 600mm x 17mm.

This pre-coated gypsum fibreboard can be cut down to any size, square or rectangle, for oversized pattresses or for long strips for use around access hatches or slot lights.

To make up the thickness for the 27mm system use 1 strip of the Fermacell board behind the system. To make up the thickness for the 47mm system we have cast lengths of glass reinforced gypsum to be used behind the system.

A standard hole cutter is used to create the specific hole size required for the project.

A single sheet of this pre-coated gypsum fibreboard would be sufficient to make eight 300 x 300mm pattresses and therefore this is more cost effective than buying individual pattresses.

### 3.7.5. Load Capacity

We recommend a maximum load capacity for the pattresses as follows:

200 x 200mm pattress - 5 kg

300 x 300mm pattress - 8 kg

Care must be taken to ensure the collective load of the plasterboard, acoustic plaster system and any lights or items suspended from a pattress does not exceed the load capacity for the ceiling. In the case of a metal frame ceiling with plasterboard fixed at 450mm centres is 30kg/m<sup>2</sup>.

(The Bondplast has an adhesive strength onto plasterboard of 0.1N/mm<sup>2</sup> or 10 N/cm<sup>2</sup> and this results in failure of the plasterboard. A 200mm x 200mm pattress would in theory support a load of up to 200kg and this would significantly exceed the 30kg/m<sup>2</sup> loading for a standard plasterboard ceiling).

## 3.8. TAPE

### 3.8.1. Product Description

Acoustic Separation Tape is a self-adhesive paper tape with a waxed surface on one side and a narrow self-adhesive strip on the reverse. Acoustic Separation Tape prevents the Acoustic Joint filler and Acoustic Topcoat bonding to adjoining surfaces.

Acoustic Airtight Tape provides a tear resistant, flexible airtight seal around light fittings, air conditioning ducts and other fixtures and fittings when installing the Armourcoat Acoustic system. Acoustic Airtight Tape is a flexible fabric reinforced plastic tape coated with pressure sensitive adhesive for good adhesion to most surfaces.

### 3.8.2. Usage

Acoustic Separation Tape should be used when applying the Armourcoat Acoustic Plaster System directly up against adjoining surfaces, such as plastered walls or joinery work where a shadow gap is not being used.

Armourcoat Acoustic Plaster System has to be porous to allow a passage of air so that the sound energy can be transmitted through the plaster surface and absorbed in the mineral layer below.

It is necessary for the air to pass into the material but it is not desirable for the air to pass through the system into the void behind. For suspended ceilings it is therefore necessary to create an airtight seal around all fixtures and fittings to prevent airflow between the room and the ceiling void as this will lead to isolated areas of discolouration.

The discolouration occurs if air is constantly passing through the Armourcoat Acoustic Plaster System and the fine particles of dust in the air are filtered by the surface of the Armourcoat Acoustic Plaster System to leave a dust residue on the surface.

### 3.8.3. Dimensions

Acoustic Separation Tape is a 65mm wide paper tape.

Length - 50m per roll

Acoustic Airtight Tape is 60mm wide with 40/20 fold for sealing at right angles.

Length - 25m per roll

### 3.8.4. Installation

Acoustic Separation Tape: Ensure the surface is dry and free of dust. Fix the tape in place ensuring that it will sit below the final finished layer. On completion of the final finish coat any excess tape can be trimmed off with a sharp blade.

Surfaces to which the Acoustic Airtight Tape is being adhered must be dry and free from dust and grease. If the surface is dusty or friable, it is advisable to apply a primer first. A firm pressure is required and the greater the pressure applied the better the adhesion.

## 3.9. DETAILING

### 3.9.1. Beading

Armourcoat offers a range of plastic beads that are well suited for the System. These are:

- Armourcoat Acoustic Corner Bead
- Armourcoat Acoustic Splay Angle Bead
- Armourcoat Acoustic Z Profile Shadow Gap Bead
- Armourcoat Acoustic Arch Corner Bead for Curves

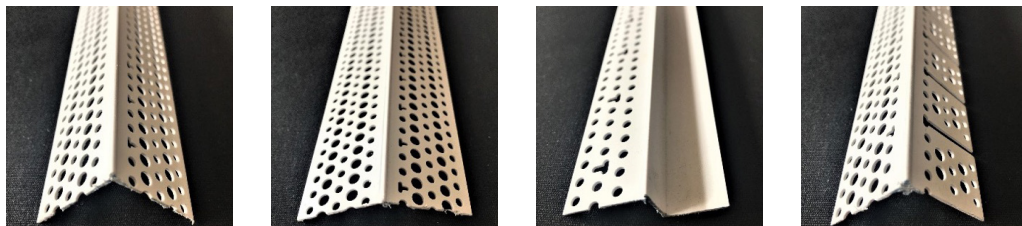

Armourcoat plastic beads are supplied in 3.05m lengths.

In addition to the plastic beads, Armourcoat recommends aluminium beads. See Supply List below.

The QIC trims Armourcoat recommends are the R10, R12, RD15, E12 and E25.

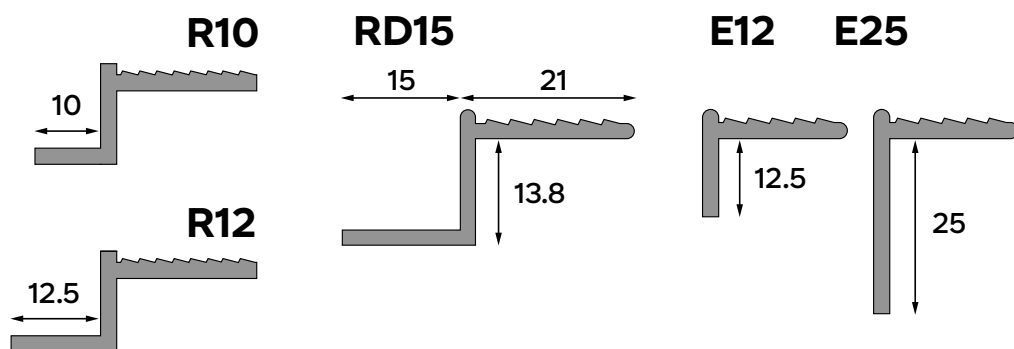

Armourcoat can supply these beads to order.

The main advantage of the aluminium trims is that they are less flexible and are therefore ideal for creating long edge runs that are perfectly straight.

The main disadvantage of aluminium beads is that they are heavier. When installing them with adhesive it is usually necessary to put in some temporary screws to hold it in place whilst the spray glue is going hard.

### 3.10. SITE REQUIREMENTS

#### 3.10.1. Work Conditions

Armourcoat Acoustic Mineral Wood Board coated with Armourcoat Basecoat are delivered to site on protected shrink-wrapped pallets. The Armourcoat Acoustic Topcoat is delivered in 24kg tubs on pallets. Armourcoat Acoustic components must be safely and securely stored awaiting installation and during installation. Empty pallets and empty tubs will be disposed into site refuse facilities provided by the contractor. Clean water and suitable power supply must be available throughout the installation program.

Areas to receive Armourcoat Acoustic must be ready as described in Substrate Preparation above and free from obstruction to include other trades. The applicator must have uninterrupted access to its working areas throughout the installation program.

Site temperature should be maintained as constant as possible and always above a minimum of 12°C. The optimum working temperature is between 15 - 25°C. At temperatures above 25 °C the working time will be reduced, and this may affect the maximum achievable area. The maximum relative air humidity and moisture level must not exceed 75%.

#### 3.10.2. Exposure of Surface to Acute Lighting

In situations where the finished surface will be exposed to acute lighting from windows or cross lighting it is vital that the final lighting is in place at the point of application. If the natural lighting from windows will be obscured by the scaffold during the installation process, then a powerful source of lighting must be put in place at an acute angle to the surface to be finished. The surface of the Armourcoat Acoustic panels should be carefully inspected during and after sanding with this strong and acute cross light so that any imperfections or deviations in the surface can be addressed before the Armourcoat Acoustic Topcoat is applied to the surface.

The cross lighting must also remain in place whilst the Armourcoat Acoustic Topcoat is being applied.

### 3.11. INSTALLATION PROCESS TIMELINE

	DAY 1	DAY 2	DAY 3	DAY 4	DAY 5
Fix Armourcoat Acoustic panels with adhesive	X				
Apply Armourcoat Acoustic Filler to seams	X				
Drying		X		X	
Sanding joints and face of panels			X		
Application of Acoustic Topcoat paster			X		
Installation of lights etc					X

These are based upon filling standard joints with good drying conditions of 20°C and RH of 50% or below and modest air circulation.

Where the board filler has been applied to a thickness of more than 7mm or there is high humidity and or lower temperatures the drying periods will increase.

In cold conditions (12 - 15°C) the drying time for the filler and topcoat plaster can be several days or more. the Armourcoat operatives will use a digital moisture meter to determine if the filler and topcoat are fully dry.

### 3.12. OPTIONAL SURFACE PROTECTION

Where additional surface protection is required or in situations where the Armourcoat Acoustic Plaster System is likely to come into contact with water (e.g. swimming pool ceilings) we recommend the application of Armourcoat Armoursil Impregnator.

Armourcoat Armoursil Impregnator is a solvent free, siloxane based water repellent impregnator for mineral based coatings.

### 3.13. DIAGRAMS

The specification is for guidance only. It describes good working practice. It does not claim to be the right or only method to provide a solid substrate and is made without responsibility for the execution of the work. Build quality is the responsibility of the installer/builder.

#### 3.13.1. System Details

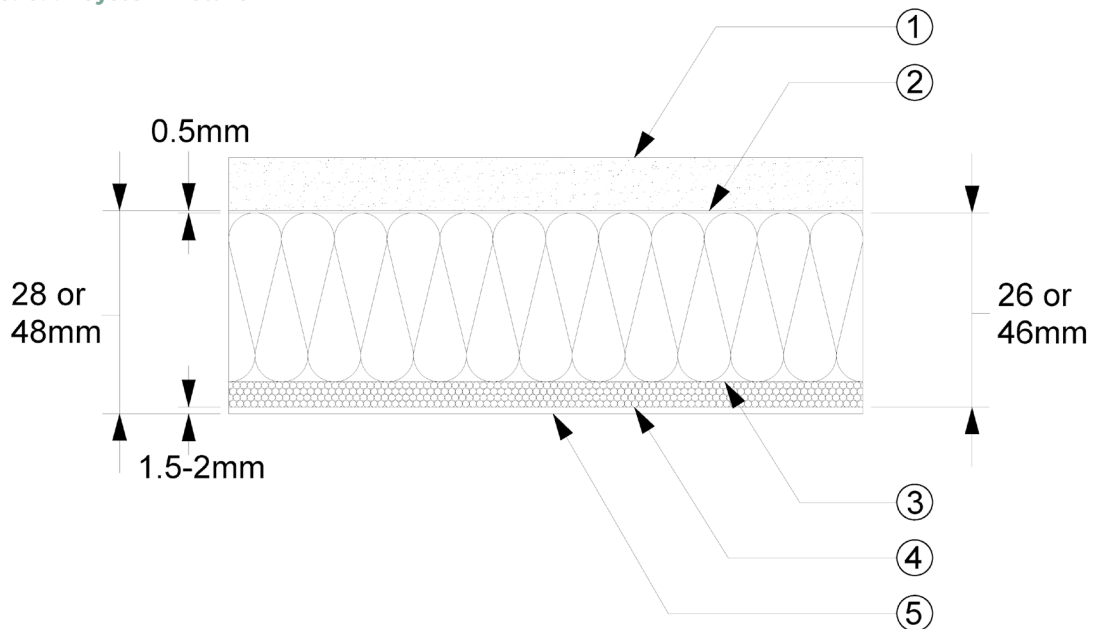

- 1 Plasterboard Substrate
- 2 Armourcoat Bondplast (0.5mm)
- 3 Mineral Wool Panel (20/40mm)
- 4 Armourcoat Acoustic Board Coating (6mm)
- 5 Armourcoat Acoustic Topcoat (2mm)

### 3.13.2. Junction Detail

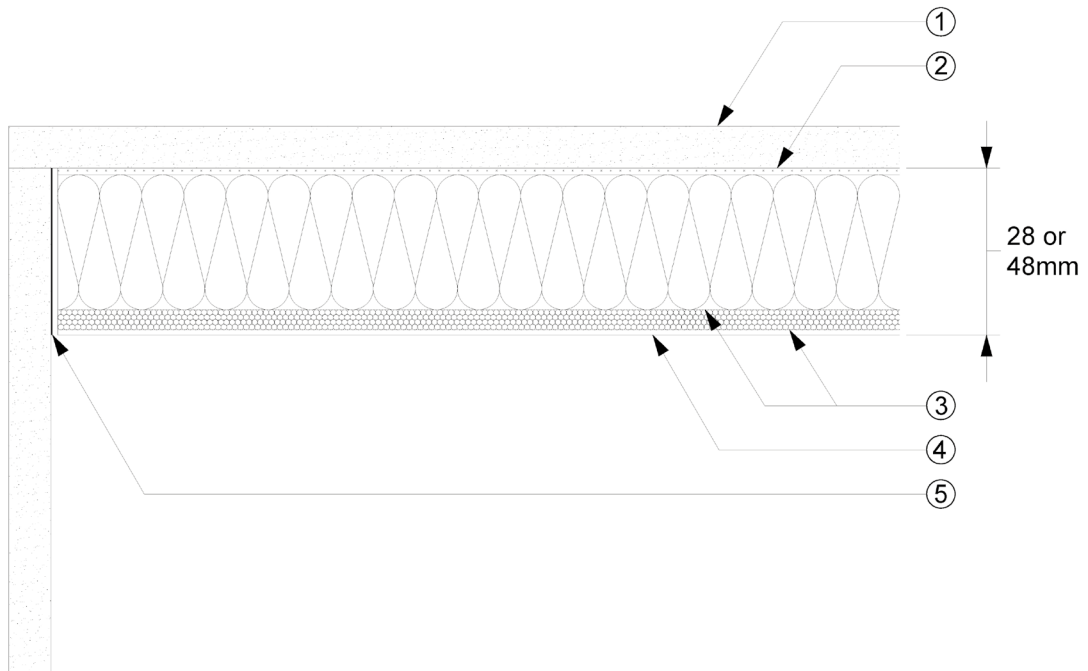

- 1 Plasterboard Substrate
- 2 Armourcoat Bondplast (0.5mm)
- 3 Armourcoat Precoated Mineral Wool Board
- 4 Armourcoat Acoustic Topcoat (2mm)
- 5 Separation Tape



### 3.13.3. External Corner Detail

- 1 Plasterboard Substrate
- 2 Armourcoat Bondplast (0.5mm)
- 3 Armourcoat Precoated Mineral Wool Board
- 4 Armourcoat Acoustic Topcoat (2mm)
- 5 External Angle Bead (White UPVC)

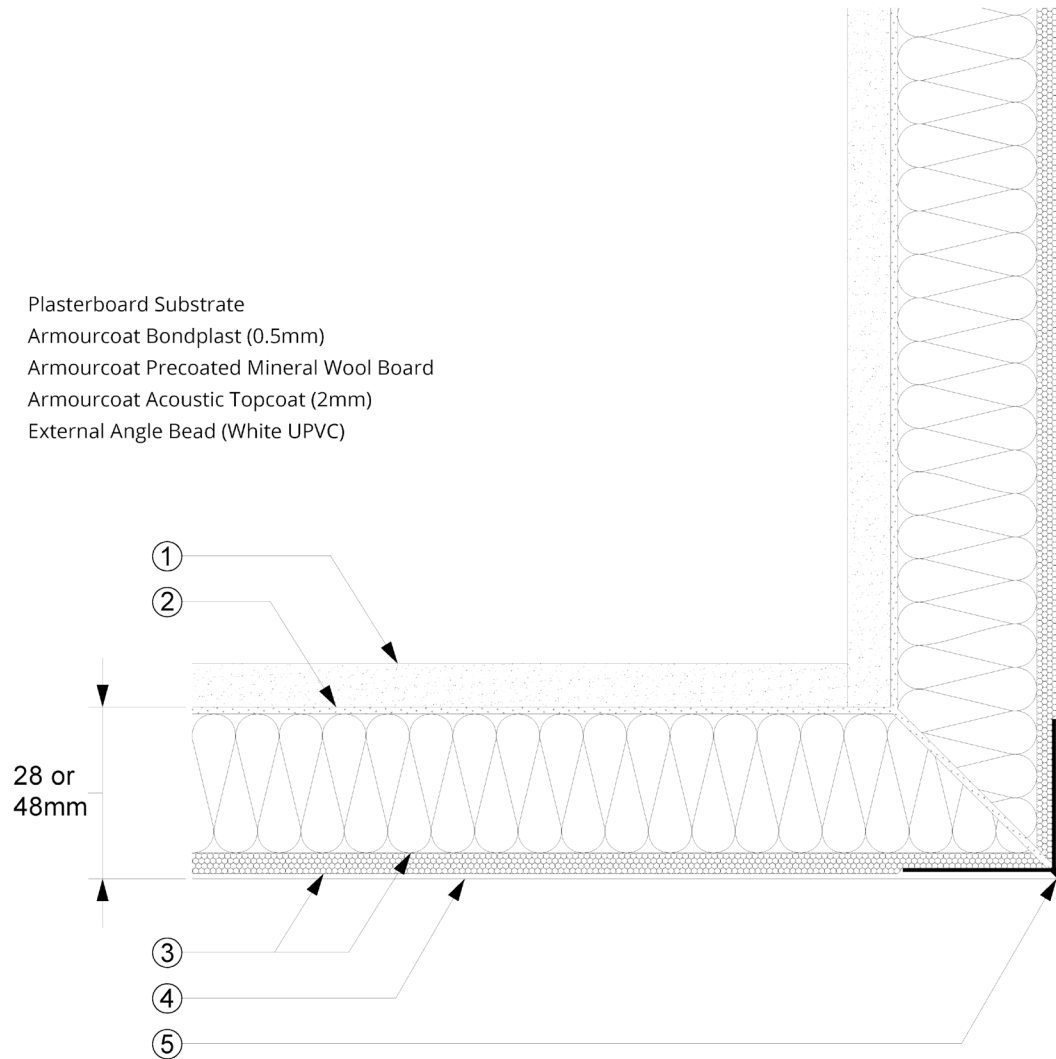

### 3.13.4. Shadow Gap Detail

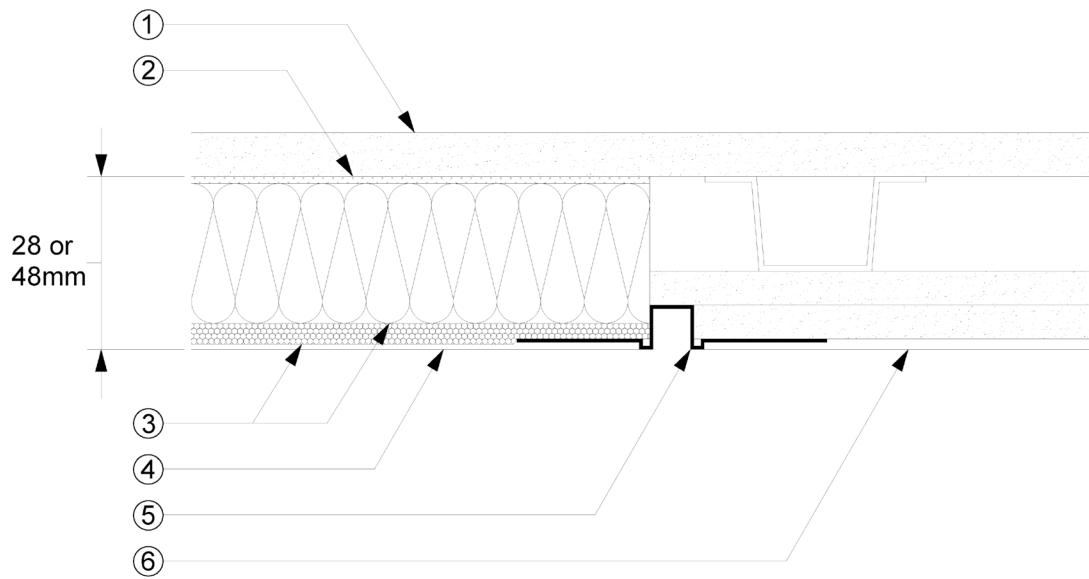

- 1 Plasterboard Substrate
- 2 Armourcoat Bondplast (0.5mm)
- 3 Armourcoat Precoated Mineral Wool Board
- 4 Armourcoat Acoustic Topcoat (2mm)
- 5 Shadow Gap Bead (UPVC)
- 6 Painted Plaster or Drywall Compound

### 3.13.5. Mounting pad with recessed downlight detail

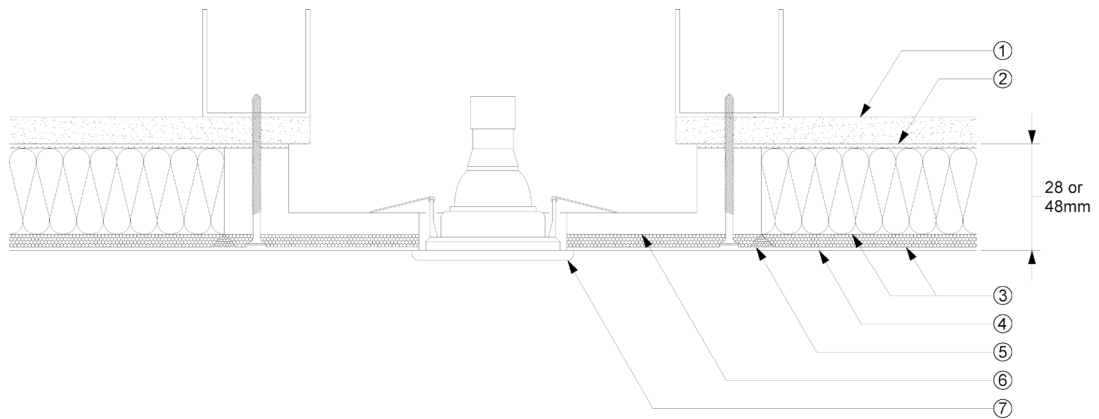

- 1 Plasterboard Substrate
- 2 Armourcoat Bondplast (0.5mm)
- 3 Armourcoat Precoated Mineral Wool Board
- 4 Armourcoat Acoustic Topcoat (2mm)
- 5 Armourcoat Joint Filler
- 6 Armourcoat Precoated Mounting Pad
- 7 Recessed Down Light

### 3.13.6. Sprinkler detail

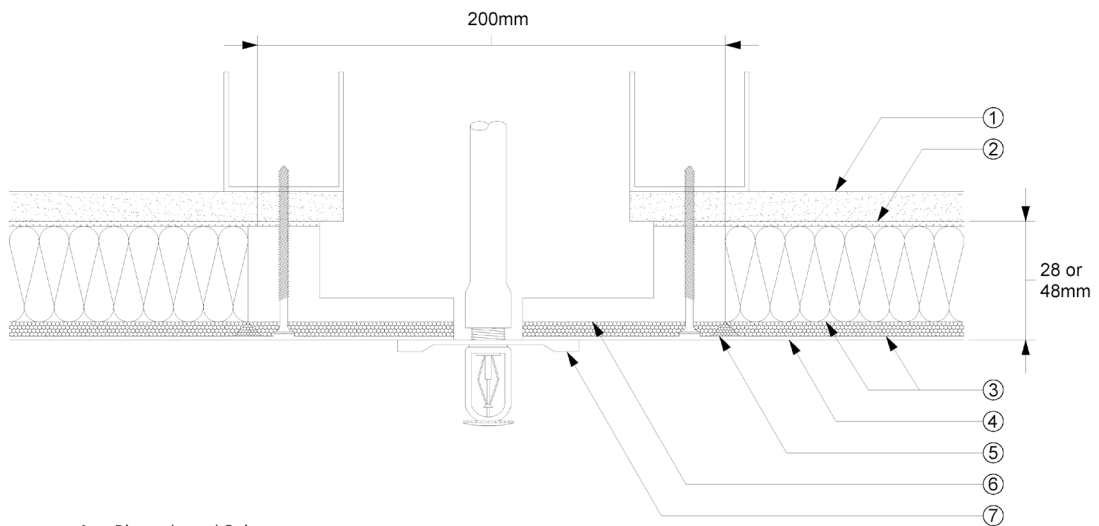

- 1 Plasterboard Substrate
- 2 Armourcoat Bondplast (0.5mm)
- 3 Armourcoat Precoated Mineral Wool Board
- 4 Armourcoat Acoustic Topcoat (2mm)
- 5 Armourcoat Joint Filler
- 6 Armourcoat Precoated Mounting Pad
- 7 Sprinkler Head

### 3.13.7. Perimeter shadow gap detail

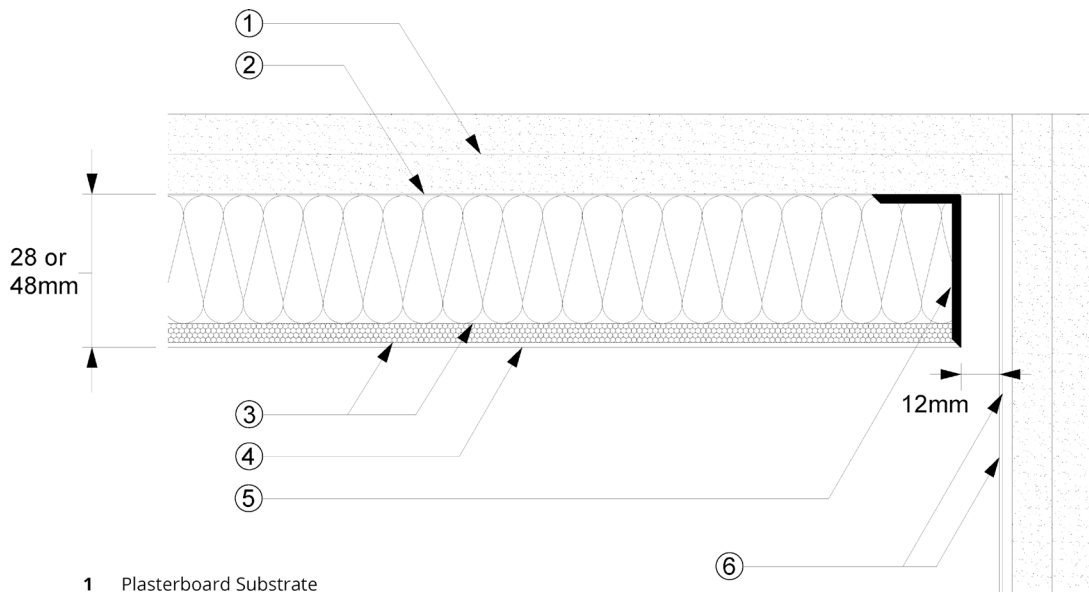

- 1 Plasterboard Substrate
- 2 Armourcoat Bondplast (0.5mm)
- 3 Armourcoat Precoated Mineral Wool Board
- 4 Armourcoat Acoustic Topcoat (2mm)
- 5 L Section Edge Trim
- 6 Taped, Jointed & Sealed P/B + 1 mm PP Finish

### 3.13.8. Slot lighting detail

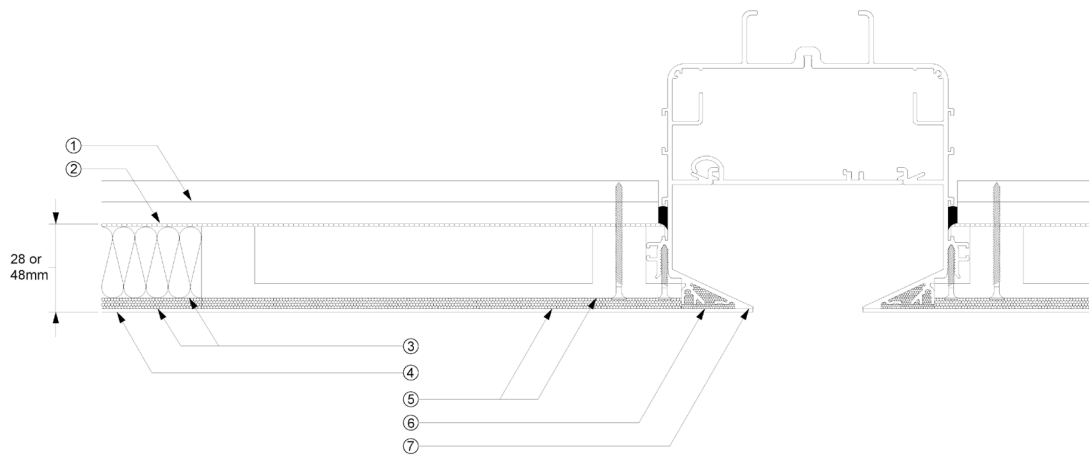

- 1 Plasterboard Substrate
- 2 Armourcoat Bondplast (0.5mm)
- 3 Armourcoat Precoated Mineral Wool Board
- 4 Armourcoat Acoustic Topcoat (2mm)
- 5 Armourcoat Slot Light Pattress
- 6 Armourcoat Acoustic Filler
- 7 Lighting Track

### 3.13.9. Trimless downlight detail

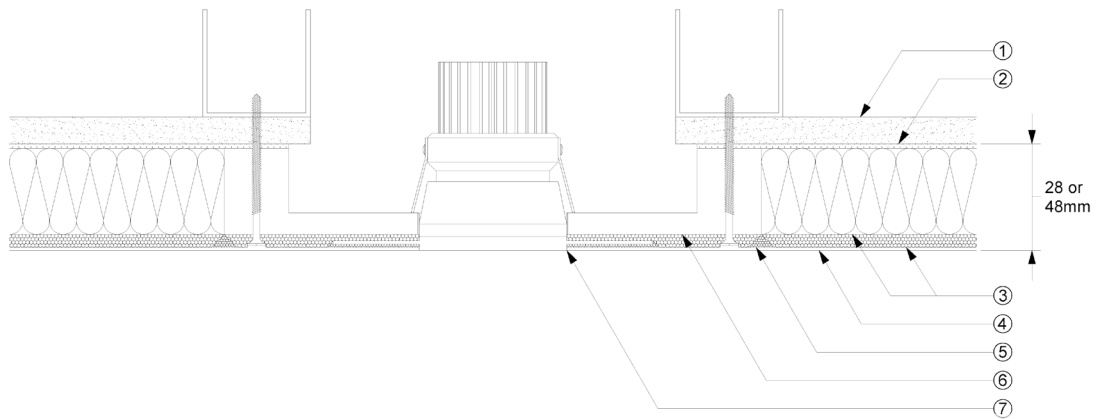

- 1 Plasterboard Substrate
- 2 Armourcoat Bondplast (0.5mm)
- 3 Armourcoat Precoated Mineral Wool Board
- 4 Armourcoat Acoustic Topcoat (2mm)
- 5 Armourcoat Joint Filler
- 6 Armourcoat Precoated Mounting Pad
- 7 Recessed Down Light

### 3.13.10. Access panel detail

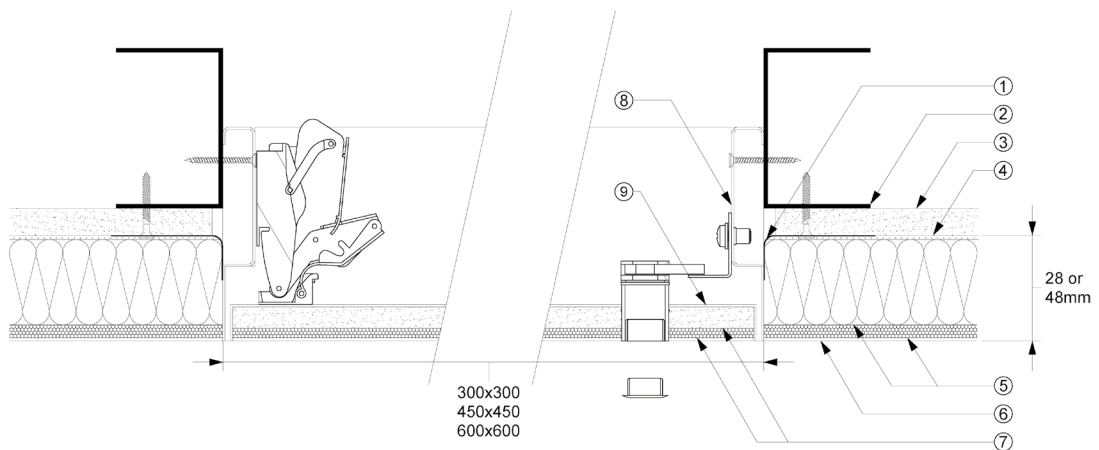

- 1 Airtight Tape
- 2 C Section Stud
- 3 Plasterboard Substrate
- 4 Armourcoat Bondplast
- 5 Armourcoat Precoated Mineral Wool Board
- 6 Armourcoat Acoustic Topcoat
- 7 10mm Fermacell board precoated with 5-6mm Acoustic Basecoat
- 8 Access Hatch Frame
- 9 Access Hatch Door

### 3.13.11. Cover up light detail

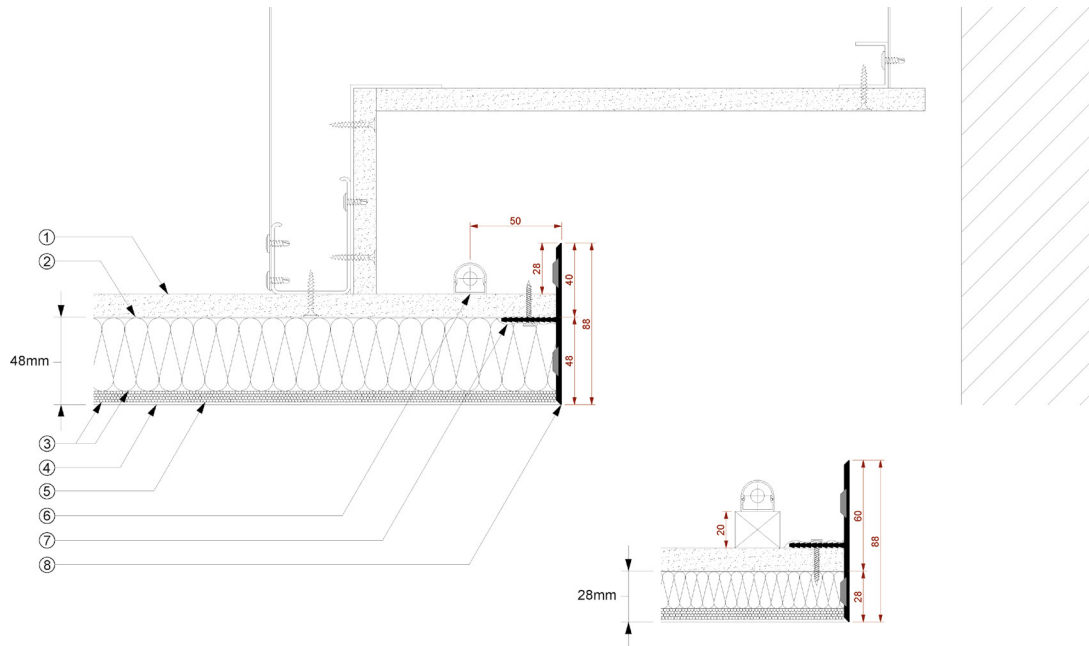

- 1 Plasterboard Substrate
- 2 Armourcoat Bondplast (0.5mm)
- 3 Armourcoat Precoated Mineral Wool Board
- 4 Armourcoat Acoustic Topcoat (2mm)
- 5 Armourcoat Acoustic Joint Filler
- 6 Trough Light - Hafele 833.74.814
- 7 Adhesive
- 8 Armourcoat Coving Trim

### 3.13.12. New coving detail

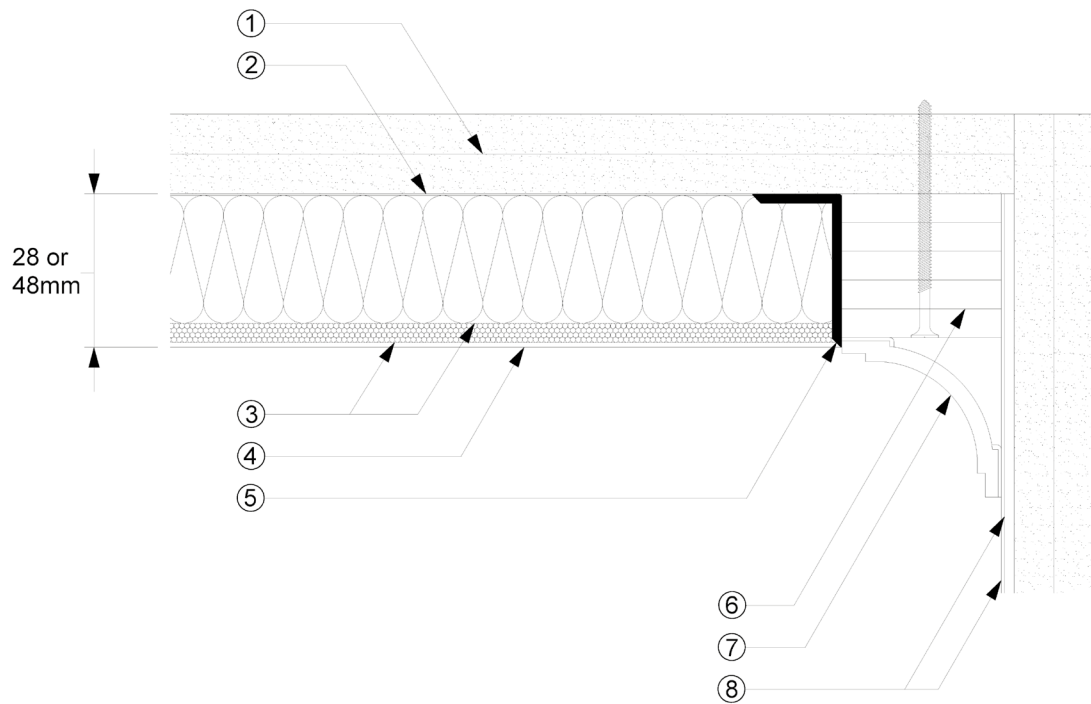

- 1 Plasterboard Substrate
- 2 Armourcoat Bondplast (0.5mm)
- 3 Armourcoat Precoated Mineral Wool Board
- 4 Armourcoat Acoustic Topcoat (2mm)
- 5 L section edge trim
- 6 Gypsum board for coving mount, installed by others prior to Armourcoat Acoustic  
Note: Coving mount must be lower than proposed L section edge trim
- 7 Coving, design of interface and installation by others post the Acoustic application
- 8 Taped & Jointed or skimmed P/B, Sealed + 1mm PP Finish

### 3.13.13. Existing coving detail

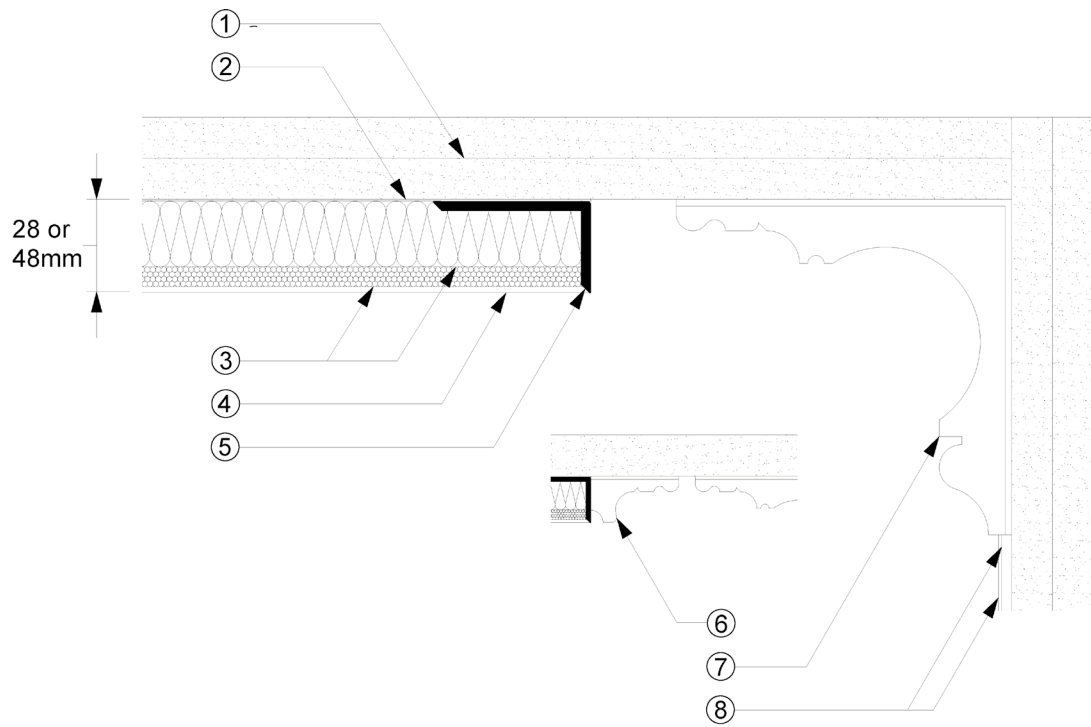

- 1 Plasterboard Substrate
- 2 Armourcoat Bondplast (0.5mm)
- 3 Armourcoat Precoated Mineral Wool Board
- 4 Armourcoat Acoustic Topcoat (2mm)
- 5 L Section edge trim
- 6 Optional custom coving interface profile
- 7 Existing Coving
- 8 Taped, Jointed & Sealed P/B + 1mm PP Finish



### 3.13.14. Heavy ceiling fittings

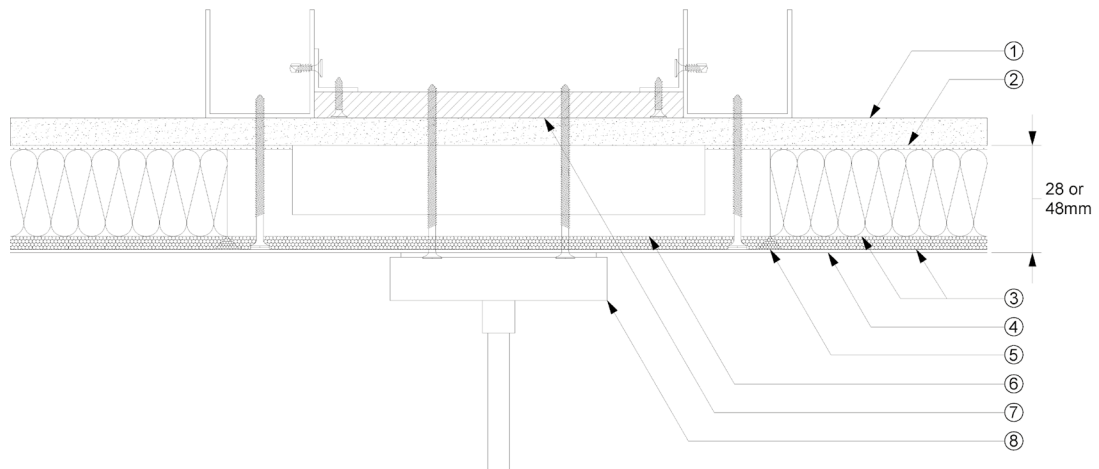

- 1 Plasterboard Substrate
- 2 Armourcoat Bondplast (0.5mm)
- 3 Armourcoat Precoated Mineral Wool Board
- 4 Armourcoat Acoustic Topcoat (2mm)
- 5 Armourcoat Acoustic Joint filler
- 6 Custom Gypsum Pattress Mounting Pad
- 7 Plywood to support light fitting - Design & Install by others
- 8 Heavy Fitting - Installed by others

## 4. CLEANING AND MAINTENANCE

Armourcoat Acoustic plaster provides a natural mineral surface made primarily from finely bound grains of white marble. Whilst it is a resilient surface there is always a chance that over time it will be subject to damage or become soiled by airborne dust and dirt. We therefore offer a range of services to clean, repair or restore the surface finish.

### 4.1. DUST REMOVAL

Areas which are subject to greater air movement (near air conditioning vents, doors etc) are likely to gradually pick up a small amount of airborne dust. This is best removed using a vacuum cleaner with a fine brush attachment.

### 4.2. STAIN REMOVAL

Any organic stains can be removed easily by the application of either a mild bleach or Peroxide cleaner. Apply to the surface using a sponge or foam roller.

### 4.3. SCUFF AND SURFACE MARKS

Scuff marks and other dirty marks on the surface can often be easily removed using a white pencil eraser or an adhesive tape such as Sellotape.

### 4.4. DAMAGE REPAIR

Any repairs of damage to the surface should be undertaken by a specialist applicator that is familiar with using the material. It is possible to make minor repairs which are very well disguised but moving light fittings or access hatches will almost always result in a visible patch repair.

### 4.5. RESTORATION

There are circumstances where it is not possible to adequately repair or clean the surface fully due to age or the extent of the damage and it is therefore necessary to undertake a full restoration.

Fortunately it is possible to remove just the final topcoat plaster and reapply a new layer of Acoustic Topcoat without the need to remove and reinstate the base panels. This will provide a brand-new appearance without affecting the acoustical performance of the system.

---

## 5. WARRANTY

A 5 year limited materials warranty for Armourcoat Acoustic System.