

ARMOURCOAT®

SUSTAINABLE LUXURY FINISHES

TECHNICAL DOCUMENT

ACOUSTIC PLASTER - FINE



CONTENTS

1. PRODUCT DESCRIPTION	3
-------------------------------	----------

2. TEST DATA	4
2.1. FIRE TESTING	4
2.2. VOLATILE ORGANIC COMPOUND (VOC) TESTING	4
2.3. ENVIRONMENTS BUILDING CERTIFICATION	5
2.4. LEED V4 CERTIFICATION CONTRIBUTION	6
2.5. ACOUSTIC PERFORMANCE	8
2.6. THERMAL PERFORMANCE	11
2.7. MOULD/MILDEW RESISTANCE	11
2.8. ENVIRONMENTAL PRODUCT DECLARATION (EPD)	11
2.9. LIVING BUILDING CHALLENGE (LBC)	11

3. SUITABLE SUBSTRATES	12
3.1. SYSTEM BUILD-UP	12
3.2. SUBSTRATE PREPARATION	13
3.3. CONSTRUCTION OF A SUSPENDED CEILING (BS EN 13964)	14
3.4. CONCRETE SUBSTRATE	14
3.5. EXISTING PLASTERED/DECORATED SURFACE	14
3.6. CURVED AND DOMED SURFACES	14
3.7. FITTINGS	15
3.8. TAPE	16
3.9. DETAILING	17
3.10. SITE REQUIREMENTS	18
3.11. INSTALLATION PROCESS TIMELINE	18
3.12. OPTIONAL SURFACE PROTECTION	19
3.13. DIAGRAMS	19

4. CLEANING AND MAINTENANCE	30
4.1. DUST REMOVAL	30
4.2. STAIN REMOVAL	30
4.3. SCUFF AND SURFACE MARKS	30
4.4. DAMAGE REPAIR	30
4.5. RESTORATION	30

5. WARRANTY	30
--------------------	-----------

ACOUSTIC PLASTER - FINE

1. PRODUCT DESCRIPTION

Armourcoat Acoustic Plaster Fine provides a smooth, seamless marble-plaster surface whilst delivering exceptional sound absorption and acoustic performance.

Drawing on extensive expertise in marble-based plaster formulations, Armourcoat has developed a refined, elegant finish that enables sound energy to pass through the surface layer, where it is absorbed and attenuated within the mineral wool substrate beneath.

The system comprises natural mineral wool panels with a factory-applied acoustic plaster basecoat. These pre-coated panels are installed on site by skilled applicators, followed by the application of a unifying acoustic undercoat plaster across the entire surface. Once dry, the system is hand-finished with a marble-based acoustic topcoat in the specified colour.

Armourcoat Acoustic Plaster Fine can be pigmented to a broad palette of colours and is suitable for both flat and curved ceilings and high-level walls.

The Armourcoat Acoustic Plaster Fine system is composed of Armourcoat Bondplast Adhesive, Armourcoat Acoustic Mineral Wool Panels with factory-coated Acoustic Basecoat Plaster, Armourcoat Acoustic Undercoat, and Armourcoat Acoustic Topcoat (AP335). Throughout this document, this system will be referred to as Armourcoat Acoustic Plaster.

Properties

- Natural mineral system
- Mineral wool panels with 80% post-consumer recycled content
- Acoustic Basecoat made from expanded glass foam granules with 72% recycled content
- Acoustic Topcoat plaster made from up to 93% recycled material
- Average System recycled content of 73%
- No Measurable VOC's
- Factory prepared panels for immediate installation
- Seamless finish with exceptional acoustic management performance
- 28mm and 48mm systems for Class A and B acoustic performance
- Resistant to mould and mildew
- Up to 100m² without joints
- A2 Fire classification
- Ultra matt surface
- Durable marble plaster finish
- Wide range of colours achievable
- Environmental Product Declaration
- Health Product Declaration
- LBC Red List Compliant

2. TEST DATA

Armourcoat Acoustic Plaster has been subjected to a wide range of Fire, VOC, acoustic, and other performance testing.

2.1. FIRE TESTING

2.1.1. European Fire Test Results

Independent tests were carried out in the UK for classification of reaction to fire performance in accordance with EN13501-1: 2018. System was tested to cover all thicknesses and in all colours.

REACTION TO FIRE CLASSIFICATION
A2 - s1, d0

2.1.2. American Fire Test Results

Test carried out in accordance with ASTM E84 - 20, Standard Test Method for Surface Burning Characteristics of Building Materials.

28mm System

TEST TYPE	RESULT
Flame Spread Index	15
Smoke Development Index	5
Flame Spread Classification	A

48mm System

TEST TYPE	RESULT
Flame Spread Index	15
Smoke Development Index	10
Flame Spread Classification	A

2.2. VOLATILE ORGANIC COMPOUND (VOC) TESTING

2.2.1. VOC Content Testing

A sample of Armourcoat Acoustic Plaster was tested by an accredited European laboratory (Eurofins) to ASTM D2369, Standard Practice for Determining Volatile Organic Compound (VOC) Content of Paints and Related Coatings.

Test Result

TEST METHOD	VOC (G/L)	VOC (LBS/GAL)	LIMIT OF DETECTION (G/L)
ISO 11890-2	<1.0	<1.0	1

2.2.2. VOC Emissions Testing

A sample of Armourcoat Acoustic Plaster was tested by Eurofins to a wide range of emissions standards including EN 16516, ISO 16000-6, AgBB and French and Belgian VOC regulations.

Evaluation of results

REGULATION OR PROTOCOL	CONCLUSION	VERSION OF REGULATION OR PROTOCOL
French VOC Regulation	A+	Decree of March 2011 (DEVL1101903D) and Arrêté of April 2011 (DEVL1104875A) modified in February 2012 (DEVL1133129A)
French CMR Components	Pass	Regulation of April and May 2009 (DEVP0908633A and DEVP0910046A)
Italian CAM Edilizia	Pass	Decree 11 October 2017 (GU n.259 del 6-11-2017)
ABG/AgBB	Pass	Ausschuss zur gesundheitlichen Bewertung von Bauprodukten (June 2021)
Belgian Regulation	Pass	Royal decree of May 2014 (C-2014/24239)
Indoor Air Comfort®	Pass	Indoor Air Comfort 7.0 of May 2020
BREEAM International	Exemplary Level	BREEAM International New Construction v2.0 (2016)
LEED v4.1 BETA	Pass	February 2021
CDPH	Pass	CDPH/EHLB/Standard Method V1.2. (January 2017)

A sample of Armourcoat Acoustic Plaster was tested for indoor air quality following the requirements of CDPH/EHLB/Standard Method by an accredited American laboratory.

ENVIRONMENT	PRODUCT USAGE	PRODUCT SURFACE AREA	ROOM VOLUME	VENTILATION RATE (ACH)	PRODUCT COMPLIANCE
Classroom	Ceiling	89.2 m ²	231 m ³	0.82	Yes
Office	Ceiling	11.1 m ²	30.6 m ³	0.68	Yes

2.3. ENVIRONMENTS BUILDING CERTIFICATION

BREEAM International – Exemplary status for VOC Emissions

CDPH - CDPH/EHLB/Standard Method V1.2. (January 2017)

Full Certificates supplied on Request.



2.4. LEED V4 CERTIFICATION CONTRIBUTION

LEED (Leadership in Energy and Environmental Design) is a global green building certification program developed by the US Green Building Council. To achieve LEED certification, projects must satisfy all the prerequisite and desired credit requirements.

The performance of the project, when measured against these criteria, determines a certification status of Silver, Gold, or Platinum.

Armourcoat is committed to sustainability across all aspects of its business. We strive to formulate all our products without VOC's or solvents and utilize recycled materials as widely as possible.

ENERGY AND ATMOSPHERE (EA)

OPTIMIZED ENERGY PERFORMANCE

EA Credit (1-20 points)

INTENT: to achieve increased energy performance and to reduce the environmental impact associated with excessive energy use and reduce stratospheric ozone depletion.

Armourcoat Acoustic recycled mineral wool panels and Armourcoat Acoustic Basecoat provide excellent thermal insulation which contributes to the reduction of heating and cooling energy used.

Armourcoat Acoustic Panels provide the following U values:

28mm system – 1.35 w/m² K

48mm system - 0.72 W/m² K

MATERIALS AND RESOURCES (MR)

INTENT: to consider the entire life cycle of the building, from extraction and manufacturing, to transport, operations, maintenance and eventually the end of life, with the aim of minimizing the total embodied energy within a building.

ENVIRONMENTAL PRODUCT DECLARATIONS

MR Credit (1-2 points)

INTENT: to encourage the use of products and materials for which life cycle information is available and that have environmentally, economically, and socially preferable life cycle impacts.

APPLICATION: Armourcoat has undertaken a full life cycle analysis for the Acoustic Plaster System and has independently verified and published EPDs for the complete system.

SOURCING OF RAW MATERIALS

MR Credit (1-2 points)

INTENT: to encourage the use of products and materials for which life cycle information is available and that have environmentally, economically, and socially preferable life cycle impacts.

APPLICATION: Armourcoat has undertaken a full life cycle analysis for its Acoustic Plaster System and has independently verified and published EPD's for the complete system.

Armourcoat Acoustic Mineral Wool Panels are made from recycled manufacturing and construction waste and the Armourcoat Acoustic Basecoat and Undercoat contain more than 90% post-consumer recycled plate glass.

Armourcoat Acoustic Topcoat contains more than 94% pre-consumer recycled marble and has an organic content of less than 3%.



MATERIAL INGREDIENTS

MR Credit (1-2 points)

INTENT: to encourage the use of products and materials for which life cycle information is available and that have environmentally, economically, and socially preferable life cycle impacts.

APPLICATION: Armourcoat discloses all chemical product ingredients in the system and has a HPD Version 2.2 (Health Product Declaration) that confirm the absence of harmful substances.

All materials in Armourcoat Acoustic Plaster have been screened against the Living building Challenge (LBC) red list materials as part of the HPD generation. Ingredients screened down to 0.1% (1000 ppm).

CONSTRUCTION AND DEMOLITION WASTE MANAGEMENT

MR Credit (1-2 points)

INTENT: to reduce construction and demolition waste disposed of in landfills and incineration facilities through waste prevention and by reusing, recovering, and recycling materials and conserving resources for future generations.

APPLICATION: in a typical installation, less than 2% of the panels are discarded, as the small l as offcuts can be used in a patchwork and then overcoated with the undercoat to provide a flat surface for the topcoat.

Any unused panel scraps are accepted in mixed glass recycling facilities as both the panel and the board coating are more than 90% recycled glass.

Undercoat granules are supplied in recycled paper sacks rather than buckets and these can be recycled into wastepaper.

The plastic pails for Armourcoat Acoustic Topcoat can be easily cleaned and recycled as plastic waste.

Any unused materials, other than Armourcoat Acoustic Topcoat that has been tinted to a nonstandard colour, are saved for use on other projects.

INDOOR ENVIRONMENTAL QUALITY (EQ)

INTENT: to contribute to the comfort and well-being of all building occupants by establishing minimum standards for indoor air quality.

LOW EMITTING MATERIAL

EQ Credit (1-3points)

INTENT: to reduce the concentration of chemical contaminants that can damage air quality and the environment and to protect health, productivity and comfort of installers and building occupants.

APPLICATION: Armourcoat Acoustic Topcoat was tested for VOC content to ISO 11890-2 and achieved <1g/l which is below the limit of detection.

Armourcoat Acoustic Plaster was tested for Indoor Air Quality Emissions by Eurofins and achieved a pass.

Armourcoat Acoustic Plaster was tested in April 2021 following the requirements of CDPH Standard Method and is compliant with CA section 01350 and CDPH standard V1.2.

THERMAL COMFORT

EQ Credit (1 point)

INTENT: to promote occupant productivity, comfort and well-being by providing thermal comfort.

APPLICATION: Armourcoat recycled mineral wool panels and board coating provide excellent thermal insulation which contributes to the reduction of heating and cooling energy used and affords occupants greater thermal comfort in a conditioned space with lower heating and cooling energy use.

Armourcoat Acoustic Panels provide the following U values:

28mm system – 1.35 w/m² K

48mm system - 0.72 W/m² K

INTERIOR LIGHTING

EQ Credit (1-2 points)

INTENT: to promote occupant productivity, comfort, and well-being by providing high quality lighting.

APPLICATION: Armourcoat Acoustic Topcoat is made from fine recycled white marble granules, is an excellent reflective white surface which contributes to the reduction in lighting energy consumption. L value 90 (LAB).

ACOUSTIC PERFORMANCE

EQ Credit (1-2 points)

INTENT: to promote occupant productivity, comfort and well-being by reducing reverberation through effective acoustic design.

APPLICATION: Armourcoat Acoustic Plaster will significantly reduce the reverberation time across a wide range of frequencies due to its outstanding sound absorption qualities.

Tested to EN ISO 354 and ASTM C423-17:

28mm Acoustic Plaster System

NRC - 0.80

Alpha W - 0.80

SAA - 0.82

48mm Acoustic Plaster System

NRC - 0.90

Alpha W - 0.95

SAA - 0.92

2.5. ACOUSTIC PERFORMANCE

Armourcoat Acoustic Plaster offers outstanding sound absorption over a wide range of frequencies.

Independent tests were carried out in the UK on Armourcoat Acoustic Plaster to determine the Sound Absorption Coefficient (α_s), conducted in accordance with European Standard EN ISO 354. Single figure ratings of sound absorption performance, known as the Weighted Sound Absorption Coefficient (α_w), Sound Absorption Class, Sound Absorption Average (SAA) and Noise Reduction Coefficient (NRC) are derived from these measurements in accordance with European Standard EN ISO 11654 and American Standard ASTM C423-17. Tests were carried out by the AIRO Acoustics Laboratory, a UKAS accredited testing laboratory No. 0483, on 18th December 2019 and 22nd April 2020. Armourcoat Acoustic Plaster achieved BS EN ISO 354:2003 Weighted Sound Absorption Coefficient (α_w) of 0.80, class B (28mm system) to 0.95, class A (48mm system).

THICKNESS	EN ISO 354:2003	CLASS	ASTM C423-17	NOISE REDUCTION COEFFICIENT (NRC)
	WEIGHTED SOUND ABSORPTION COEFFICIENT (α_w)		SOUND ABSORPTION AVERAGE (SAA)	
28mm	0.80	B	0.82	0.80
48mm	0.95	A	0.92	0.90

2.5.1 28mm System with AP335 Topcoat – Sound Absorption Coefficient to EN ISO 354:2003

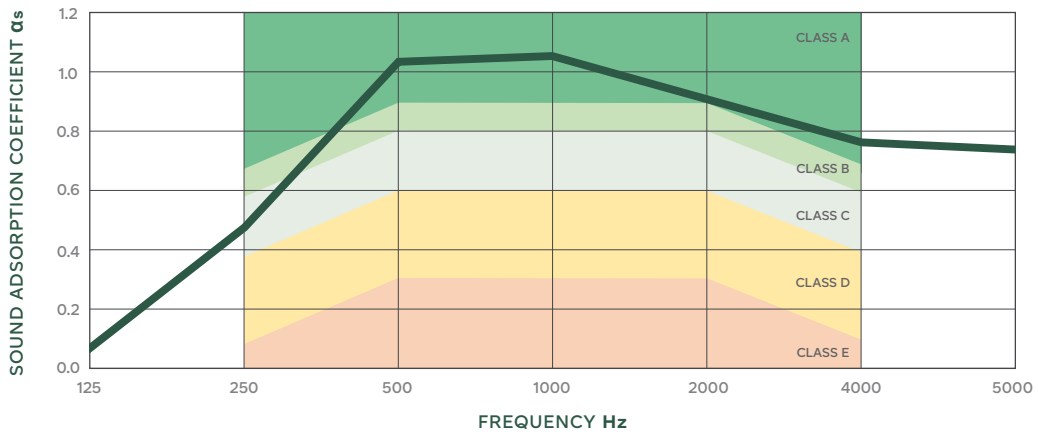

BS EN ISO 11654:1997

Sound Absorption Class: **B**

$\alpha_w = 0.80$

NRC = **0.80**

FREQUENCY Hz	ABSORPTION α_s	α_p	FREQUENCY Hz	ABSORPTION α_s	α_p
100	0.05		800	1.05	
125	0.09	0.10	1000	1.05	1.00
160	0.20		1250	1.01	
200	0.32		1600	0.94	
250	0.49	0.50	2000	0.91	0.90
315	0.65		2500	0.84	
400	0.84		3150	0.82	
500	1.02	0.95	4000	0.79	0.80
630	1.05		5000	0.76	

2.5.2 48mm System with AP335 Topcoat – Sound Absorption Coefficient to EN ISO 354:2003

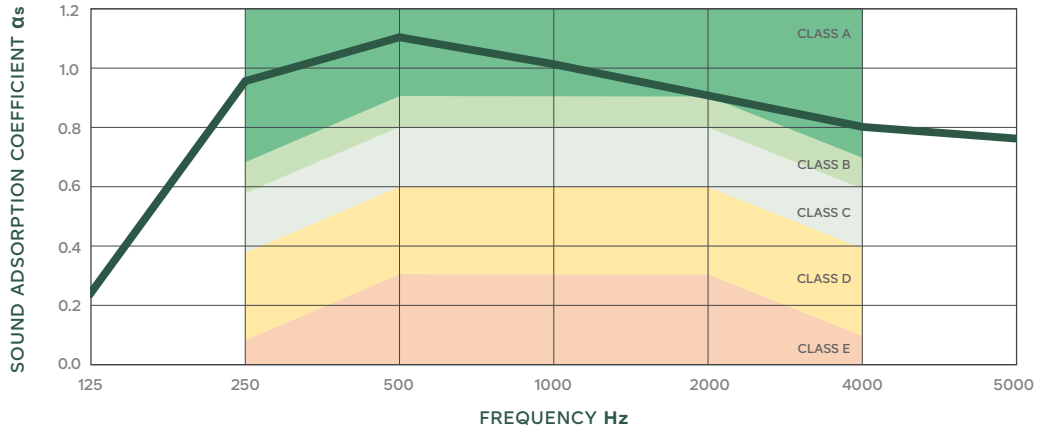

BS EN ISO 11654:1997

Sound Absorption Class: **A**

$\alpha_w = 0.95$

NRC = **0.90**

FREQUENCY Hz	ABSORPTION α_s	α_p	FREQUENCY Hz	ABSORPTION α_s	α_p
100	0.12		800	1.05	
125	0.24	0.30	1000	1.02	1.00
160	0.48		1250	0.98	
200	0.64		1600	0.94	
250	0.90	0.85	2000	0.90	0.90
315	1.01		2500	0.90	
400	1.07		3150	0.85	
500	1.11	1.00	4000	0.82	0.80
630	1.06		5000	0.79	

2.6. THERMAL PERFORMANCE

Armourcoat Acoustic Plaster also provided insulation with excellent thermal performance.

SYSTEM THICKNESS (MM)	GLASSWOOL LAMBDA (W/MK)	GLASSWOOL THICKNESS (MM)	BOARD COATING LAMBDA (W/MK)	BOARD COATING THICKNESS (MM)	R VALUE (M2 K/W)	U VALUE (W/M2 K)
28	0.035	22	0.05	6	0.74	1.35
48	0.035	42	0.05	6	1.38	0.72

2.7. MOULD/MILDEW RESISTANCE

ASTM D 3273-16 Standard Test Method for Resistance to Growth of Mould on the Surface of Interior Coatings in an Environmental Chamber.

PLASTER	FINISH	POST TREATMENT	WEEK 1	WEEK 4
Armourcoat Acoustic	AP335	-	10/10/10	10/10/10

*Rating system: 1 is very poor. 10 is no growth.

Testing was carried out by an accredited American testing laboratory.

2.8. ENVIRONMENTAL PRODUCT DECLARATION (EPD)

In accordance with ISO 14025, ISO 21930 and EN 15804 - The International EPD® System. Core environmental impact indicator EN 15804 +A2 PEF (All categories Cradle to grave).

28mm System

GWP per m² 4.17 kg CO₂ e / m² (A1- A3)

GWP per m² 4.46 kg CO₂ e / m² (A1- A5 + C1-4 & D)

48mm System

GWP per m² 6.46 kg CO₂ e / m² (A1- A3)

GWP per m² 6.76 kg CO₂ e / m² (A1- A5 + C1-4 & D)

2.9. LIVING BUILDING CHALLENGE (LBC)

Living Building Challenge (LBC) Red List Approved is a status indicating that a product is in compliance with the requirements of the LBC Challenge. Armourcoat Acoustic System has met this challenge and contains no materials that appear on the LBC Red List - March 2022.

3. SUITABLE SUBSTRATES

Armourcoat Acoustic Mineral Wool Panels can easily be cut with a handsaw or cutting blade. They are adhered to the substrate using Armourcoat Bondplast. Mix Armourcoat Bondplast to a workable consistency and apply to the back of the panels using a 6mm notched trowel. Adhere panels to the substrate in an offset block pattern making sure each panel is tightly butted up to the adjoining panels.

Armourcoat Acoustic Mineral Wool Panels can be applied over a wide range of substrates including:

- Plasterboard onto suspended frame
- GRG
- Cement board
- Direct to concrete
- Existing plastered surfaces
- Previously decorated surfaces

Armourcoat Acoustic Plaster is not suitable for application to wooden or MDF substrates or surfaces which are weak and crumbling or have flaking or peeling paint or plaster.

For old ceilings that have been previously treated with a lining paper or wallpaper it is essential to test the adhesion and treat the surface with a sealer/primer to stop the moisture from the Armourcoat Bondplast softening the adhesion of the paper.

If in doubt conduct 3 no. 100mm x 100mm pull off test to check the levels of adhesion before applying the system. (If the 100mm x 100mm can suspend a 1kg weight you have a safety factor of 12 or 1200%).

3.1. SYSTEM BUILD-UP

Armourcoat Acoustic Plaster comprises of a special mineral wool panel pre-coated with a porous mineral basecoat (Armourcoat Acoustic Basecoat) and calibrated to an exact thickness.

This board is adhered to the substrate with a gypsum adhesive and any minor discrepancies between the panels are sanded out. Acoustic undercoat is then applied to the surface to a thickness of 1-1.5 mm to fill any of the joints and create a consistent layer over the surface.

If the application of this layer shows up any unevenness in the surface it can be lightly sanded but otherwise the Acoustic Topcoat Plaster can be applied directly to the dried undercoat.

For surfaces with complex shapes of surfaces subject to very critical cross lighting we would recommend the application of a second layer of Acoustic Undercoat Plaster prior to the application of the final finish.

The undercoat must be allowed to dry fully before the application of the final topcoat layer.

3.2. SUBSTRATE PREPARATION

Armourcoat Acoustic Plaster can be applied to a wide range of substrates which should be firm and true and will not move or crack. The most common substrate for the system is plasterboard suspended on a metal frame system.

All joints should be taped with a reinforcing mesh and the joints filled flush with the surface. Skimcoat plaster or jointing compound must be fully dry. Substrates to receive the system directly must be flat and true, devoid of undulation and with all fixtures and fittings already installed by others.

Armourcoat Acoustic Panels are cut and shaped in order to accurately include and house all fixtures and fittings.

Armourcoat or its partners will check substrate quality and suitability with the contractor prior to any system installation. In the event of concerns Armourcoat or its partners will advise on any amendments required. Armourcoat takes no responsibility for substrate build and suitability for installation. Works should not commence until all necessary rectifications have been made and no further adjustments will be made to the location of lights, sprinkler heads etc. All fixtures and fittings must be installed to the necessary depth relative to the thickness of the system panels. Such detailing to be discussed at pre-order meetings between Armourcoat or its partners and the specifier/contractor.

Substrates must be solid and airtight to ensure that air only enters the system without passing through the acoustic layer into the ceiling void. Any gaps between fixtures and fittings set into the substrate must be sealed at the substrate point to prevent air movement. Vents can be introduced to allow for pressure equalisation between the ceiling void and the room or space being treated with Armourcoat Acoustic Plaster if required.

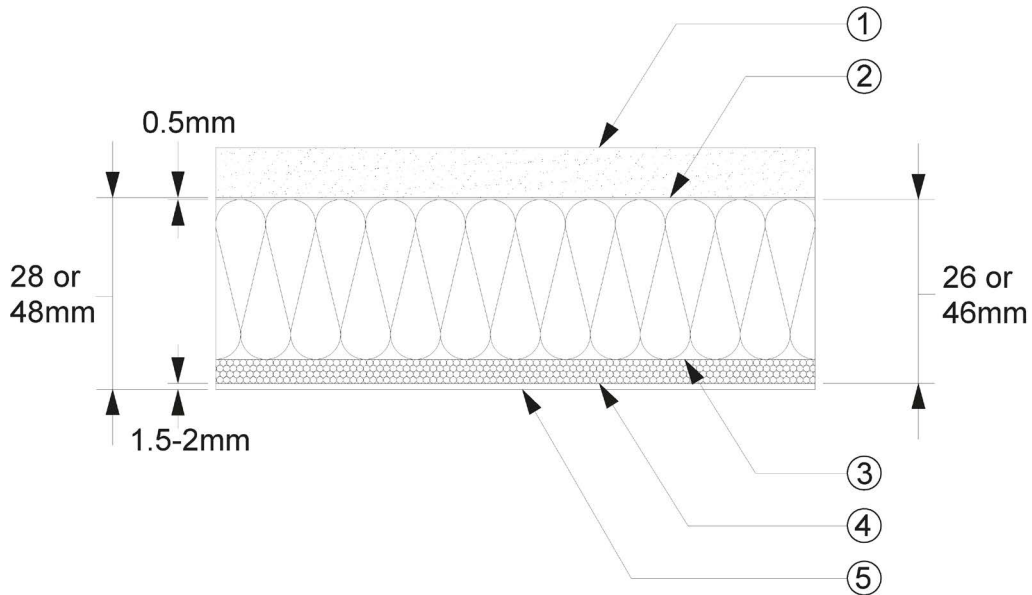

- 1 Plasterboard Substrate
- 2 Armourcoat Bondplast (0.5mm)
- 3 Mineral Wool Panel (20/40mm)
- 4 Armourcoat Acoustic Board Coating and Undercoat (5-7mm)
- 5 Armourcoat Acoustic Topcoat (2mm)

3.3. CONSTRUCTION OF A SUSPENDED CEILING (BS EN 13964)

To ensure compliance to BS EN 13964, please consult British Gypsum for load ratings to suspended ceilings systems.

3.4. CONCRETE SUBSTRATE

Ensure that the concrete surface is fully dry and free of any dust or contaminants. Ensure that the concrete surface is sufficiently flat and true and does not have surface discrepancies greater than 3mm.

3.5. EXISTING PLASTERED/DECORATED SURFACE

For existing ceilings check that the surface is sound and flat and that any paint or existing decoration is well adhered to the surface.

For old ceilings that have been previously treated with a lining paper or wallpaper it is essential to test the adhesion and treat the surface with a sealer/ primer to stop the moisture from the Armourcoat Bondplast softening the adhesion of the paper.

If in doubt conduct 3 no 100mm x 100mm pull off test to check the levels of adhesion before applying the system. (If the 100mm x 100mm can suspend a 1kg weight you have a safety factor of 12 or 1200%).

3.6. CURVED AND DOMED SURFACES

Armourcoat Acoustic Plaster can be used on both single curved and double curved surfaces.

The 48mm system is suitable for curves of down to a 3 metre radius without any modification. For tighter radius curves the mineral wool on the rear of the boards can be cut with parallel slots to increase the boards curvature. The 28mm system is suitable for curves down to a 1 metre radius.

For curved and domed surfaces subject to critical lighting it is important to take great care with the sanding process and it is advisable to apply a second layer of Acoustic Undercoat and leave this to dry fully before the application of the final acoustic Topcoat plaster.

There will be an additional cost for curved and double curved surfaces which will depend upon the complexity of each particular project.

3.7. FITTINGS

3.7.1. Pattresses

Armourcoat Acoustic Pattresses are designed to provide a stable base platform for the fixing of recessed or surface mounted light fittings, recessed speakers, cameras and alarms etc. They are fabricated from a 10mm thick fibre reinforced gypsum (Fermacell) which is pre-coated with the Armourcoat Acoustic Basecoat to the same thickness as the Armourcoat Acoustic Panels.

The pattresses have a 30mm wide perimeter that is manufactured from a resin modified glass reinforced gypsum and is bonded onto the board face with Armourcoat Bondplast. The pattresses are fixed into position with screws and Bondplast.

3.7.2. Dimensions

Armourcoat Acoustic Pattresses are available in the following standard sizes:

200 x 200mm x 27mm

200 x 200mm x 47mm

300 x 300mm x 27mm

300 x 300mm x 47mm

3.7.3. Custom Sizes

There are many situations where either larger or longer pattresses are required. Armourcoat offers a fibre reinforced gypsum panel which has been pre-coated with the Acoustic Basecoat to cater for such requirements. Dimensions are 1200mm x 600mm x 17mm.

This pre-coated gypsum fibreboard can be cut down to any size, square or rectangle, for oversized pattresses or for long strips for use around access hatches or slot lights.

To make up the thickness for the 27mm system use 1 strip of the Fermacell board behind the system. To make up the thickness for the 47mm system we have cast lengths of glass reinforced gypsum to be used behind the system.

A standard hole cutter is used to create the specific hole size required for the project.

A single sheet of this pre-coated gypsum fibreboard would be sufficient to make eight 300 x 300mm pattresses and therefore this is more cost effective than buying individual pattresses.

3.7.5. Load Capacity

We recommend a maximum load capacity for the pattresses as follows:

200 x 200mm pattress - 5 kg

300 x 300mm pattress - 8 kg

Care must be taken to ensure the collective load of the plasterboard, Armourcoat Acoustic Plaster and any lights or items suspended from a pattress does not exceed the load capacity for the ceiling. In the case of a metal frame ceiling with plasterboard fixed at 450mm centres is 30kg/m².

(The Bondplast has an adhesive strength onto plasterboard of 0.1N/mm² or 10 N/cm² and this results in failure of the plasterboard. A 200mm x 200mm pattress would in theory support a load of up to 200kg and this would significantly exceed the 30kg/m² loading for a standard plasterboard ceiling).

3.8. TAPE

3.8.1. Product Description

Acoustic Separation Tape is a self-adhesive paper tape with a waxed surface on one side and a narrow self-adhesive strip on the reverse. Acoustic Separation Tape prevents the Acoustic Joint filler and Acoustic Topcoat bonding to adjoining surfaces.

Acoustic Airtight Tape provides a tear resistant, flexible airtight seal around light fittings, air conditioning ducts and other fixtures and fittings when installing Armourcoat Acoustic Plaster. Acoustic Airtight Tape is a flexible fabric reinforced plastic tape coated with pressure sensitive adhesive for good adhesion to most surfaces.

3.8.2. Usage

Acoustic Separation Tape should be used when applying Armourcoat Acoustic Plaster directly up against adjoining surfaces, such as plastered walls or joinery work where a shadow gap is not being used.

Armourcoat Acoustic Plaster has to be porous to allow a passage of air so that the sound energy can be transmitted through the plaster surface and absorbed in the mineral layer below.

It is necessary for the air to pass into the material but it is not desirable for the air to pass through the system into the void behind. For suspended ceilings it is therefore necessary to create an airtight seal around all fixtures and fittings to prevent airflow between the room and the ceiling void as this will lead to isolated areas of discolouration.

The discolouration occurs if air is constantly passing through Armourcoat Acoustic Plaster and the fine particles of dust in the air are filtered by the surface of Armourcoat Acoustic Plaster to leave a dust residue on the surface.

3.8.3. Dimensions

Acoustic Separation Tape is a 65mm wide paper tape.

Length - 50m per roll

Acoustic Airtight Tape is 60mm wide with 40/20 fold for sealing at right angles.

Length - 25m per roll

3.8.4. Installation

Acoustic Separation Tape: Ensure the surface is dry and free of dust. Fix the tape in place ensuring that it will sit below the final finished layer. On completion of the final finish coat any excess tape can be trimmed off with a sharp blade.

Surfaces to which the Acoustic Airtight Tape is being adhered must be dry and free from dust and grease. If the surface is dusty or friable, it is advisable to apply a primer first. A firm pressure is required and the greater the pressure applied the better the adhesion.

3.9. DETAILING

3.9.1. Beading

Armourcoat offers a range of plastic beads that are well suited for the system. These are:

- Armourcoat Acoustic Corner Bead
- Armourcoat Acoustic Splay Angle Bead
- Armourcoat Acoustic Z Profile Shadow Gap Bead
- Armourcoat Acoustic Arch Corner Bead for Curves

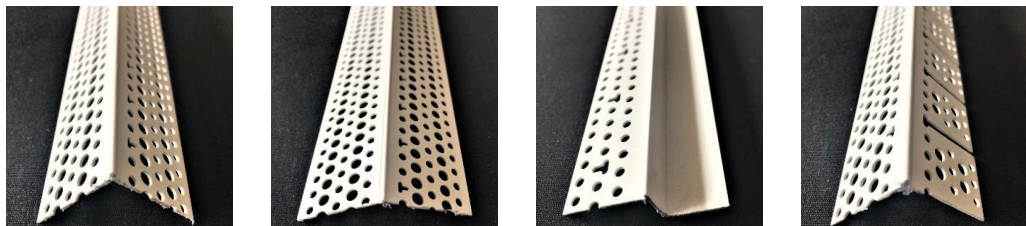

Armourcoat plastic beads are supplied in 3.05m lengths.

In addition to the plastic beads, Armourcoat recommends aluminium beads. See Supply List below.

The QIC trims Armourcoat recommends are the R10, R12, RD15, E12 and E25.

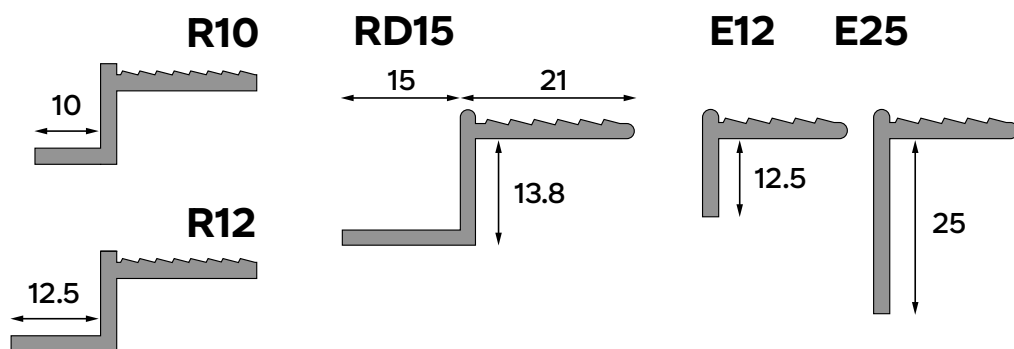

Armourcoat can supply these beads to order.

The main advantage of the aluminium trims is that they are less flexible and are therefore ideal for creating long edge runs that are perfectly straight.

The main disadvantage of aluminium beads is that they are heavier. When installing them with adhesive it is usually necessary to put in some temporary screws to hold it in place whilst the spray glue is going hard.

3.10. SITE REQUIREMENTS

3.10.1. Work Conditions

Armourcoat Acoustic Mineral Wool Panels coated with Armourcoat Acoustic Basecoat are delivered to site on protected shrink-wrapped pallets. Armourcoat Acoustic Topcoat is delivered in 24kg tubs on pallets. Armourcoat Acoustic components must be safely and securely stored awaiting installation and during installation. Empty pallets and empty tubs will be disposed into site refuse facilities provided by the contractor. Clean water and suitable power supply must be available throughout the installation program.

Areas to receive Armourcoat Acoustic Plaster must be ready as described in Substrate Preparation above and free from obstruction to include other trades. The applicator must have uninterrupted access to its working areas throughout the installation program.

Site temperature should be maintained as constant as possible and always above a minimum of 12°C. The optimum working temperature is between 15 - 25°C. At temperatures above 25 °C the working time will be reduced, and this may affect the maximum achievable area. The maximum relative air humidity and moisture level must not exceed 75%.

3.10.2. Exposure of Surface to Acute Lighting

In situations where the finished surface will be exposed to acute lighting from windows or cross lighting it is vital that the final lighting is in place at the point of application. If the natural lighting from windows will be obscured by the scaffold during the installation process, then a powerful source of lighting must be put in place at an acute angle to the surface to be finished. The surface of Armourcoat Acoustic Panels should be carefully inspected during and after sanding with this strong and acute cross light so that any imperfections or deviations in the surface can be addressed before Armourcoat Acoustic Topcoat is applied to the surface.

The cross lighting must also remain in place whilst the Armourcoat Acoustic Topcoat is being applied.

3.11. INSTALLATION PROCESS TIMELINE

	DAY 1	DAY 2	DAY 3	DAY 4	DAY 5
Fix Armourcoat Acoustic Panels with adhesive	X				
Apply Armourcoat Acoustic Undercoat	X				
Drying		X		X	
Sanding joints and face of panels	X				
Application of Acoustic Topcoat Plaster			X		
Installation of lights etc					X

These are based upon filling standard joints with good drying conditions of 20°C and RH of 50% or below and modest air circulation.

Where Acoustic Undercoat Plaster has been applied to a greater thickness or there is high humidity or lower temperatures, an extra day of drying may be necessary. Check that the undercoat is completely dry before proceeding with the topcoat application .

In cold conditions (12 - 15°C) the drying time for the filler and Topcoat Plaster can be several days or more. Armourcoat operatives will use a digital moisture meter to determine if the filler and topcoat are fully dry.

3.12. OPTIONAL SURFACE PROTECTION

Where additional surface protection is required or in situations where Armourcoat Acoustic Plaster is likely to come into contact with water (e.g. swimming pool ceilings) we recommend the application of Armourcoat Armoursil Impregnator.

Armourcoat Armoursil Impregnator is a solvent free, siloxane based water repellent impregnator for mineral based coatings.

3.13. DIAGRAMS

The specification is for guidance only. It describes good working practice. It does not claim to be the right or only method to provide a solid substrate and is made without responsibility for the execution of the work. Build quality is the responsibility of the installer/builder.

3.13.1. System Details

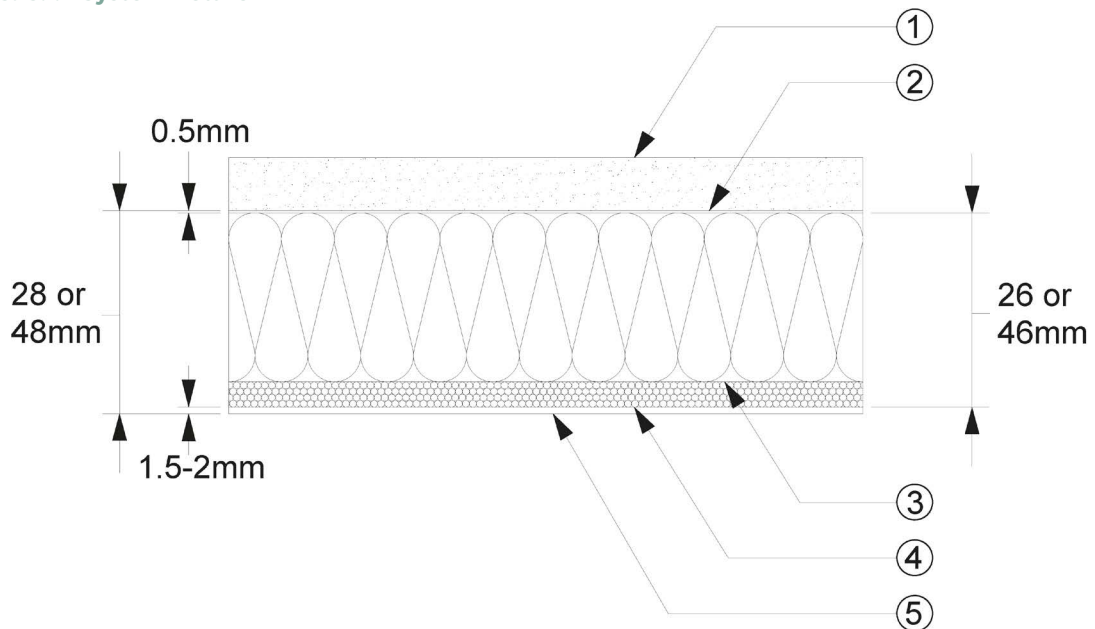

- 1 Plasterboard Substrate
- 2 Armourcoat Bondplast (0.5mm)
- 3 Mineral Wool Panel (20/40mm)
- 4 Armourcoat Acoustic Board Coating and Undercoat (5-7mm)
- 5 Armourcoat Acoustic Topcoat (2mm)

3.13.2. Junction Detail

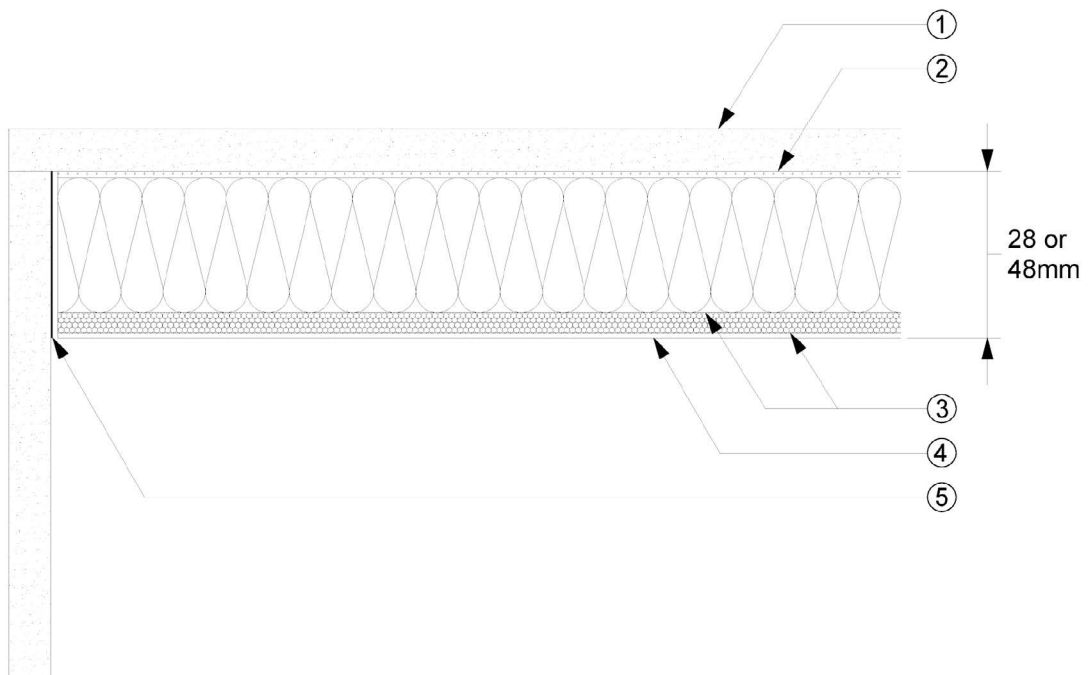

- 1 Plasterboard Substrate
- 2 Armourcoat Bondplast (0.5mm)
- 3 Armourcoat Precoated Board and Undercoat (5-7mm)
- 4 Armourcoat Acoustic Topcoat (2mm)
- 5 Separation Tape

3.13.3. External Corner Detail

- 1 Plasterboard Substrate
- 2 Armourcoat Bondplast (0.5mm)
- 3 Armourcoat Precoated Board and Undercoat (5-7mm)
- 4 Armourcoat Acoustic Topcoat (2mm)
- 5 External Angle Bead (White UPVC)

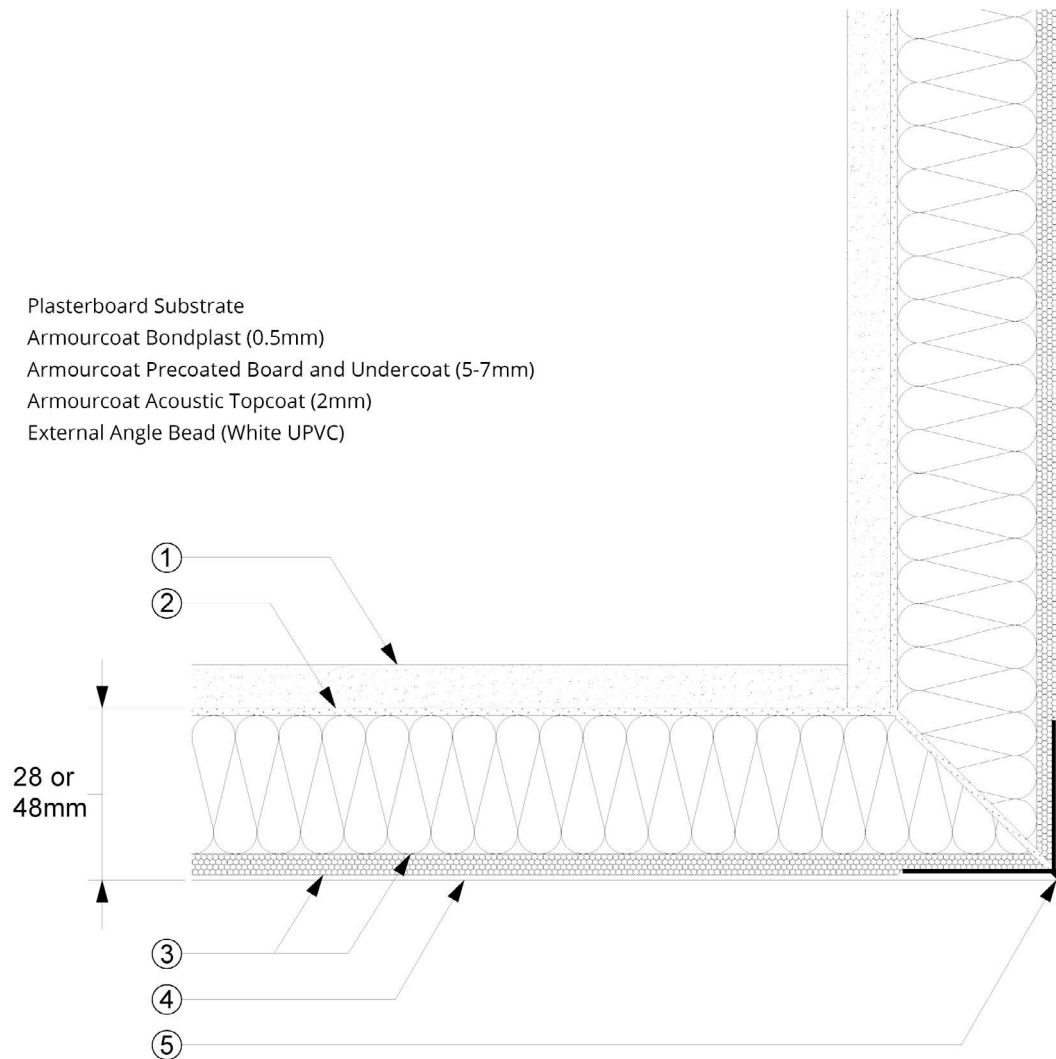

3.13.4. Shadow Gap Detail

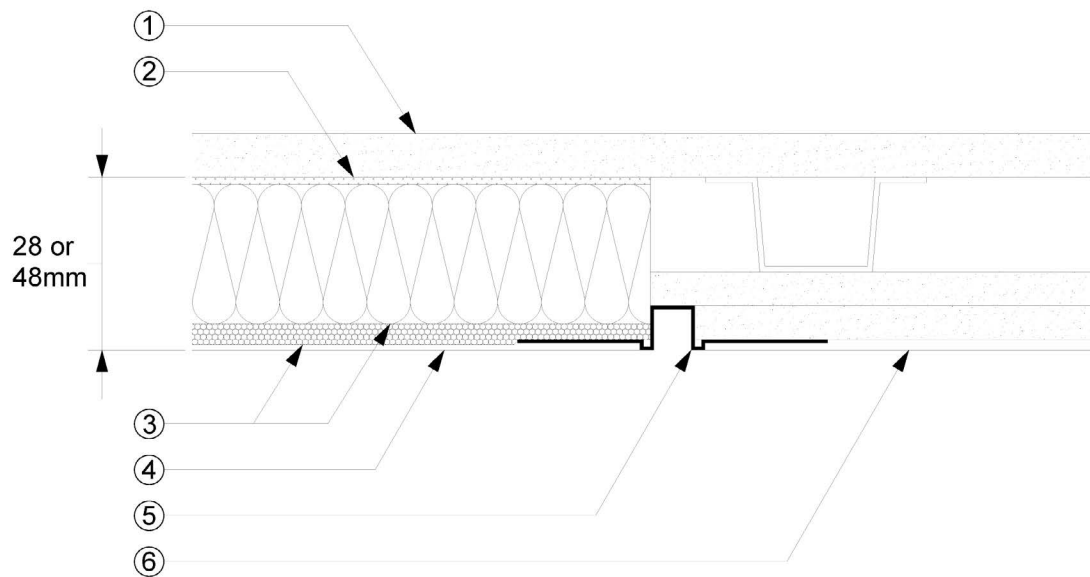

- 1 Plasterboard Substrate
- 2 Armourcoat Bondplast (0.5mm)
- 3 Armourcoat Precoated Board and Undercoat (5-7mm)
- 4 Armourcoat Acoustic Topcoat (2mm)
- 5 Shadow Gap Bead (UPVC)
- 6 Painted Plaster or Drywall Compound

3.13.5. Mounting pad with recessed downlight detail

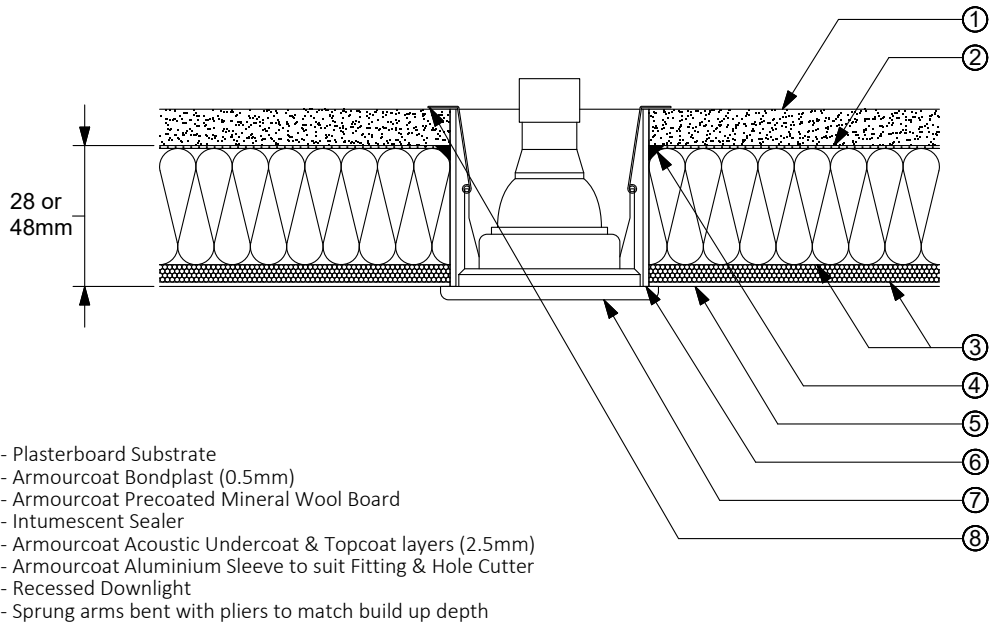

3.13.6. Sprinkler detail

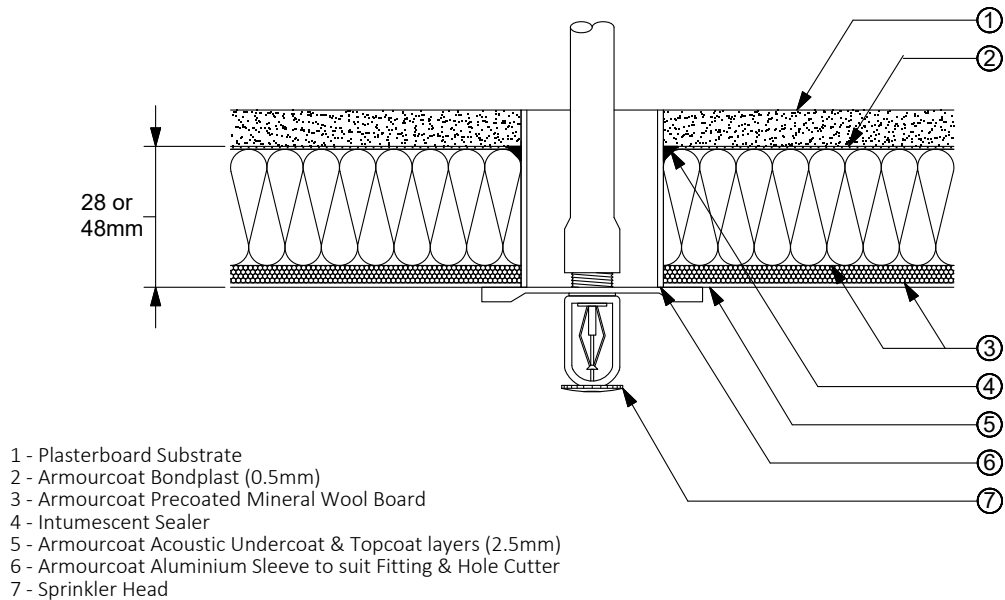

3.13.7. Perimeter shadow gap detail

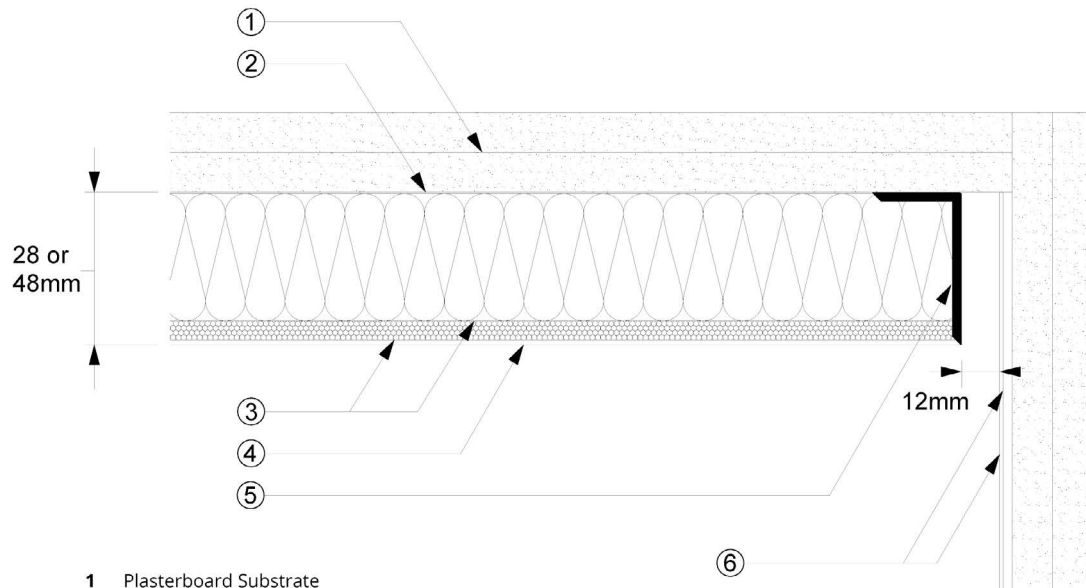

- 1 Plasterboard Substrate
- 2 Armourcoat Bondplast (0.5mm)
- 3 Armourcoat Precoated Board and Undercoat (5-7mm)
- 4 Armourcoat Acoustic Topcoat (2mm)
- 5 L Section Edge Trim
- 6 Taped, Jointed & Sealed P/B + 1mm PP Finish

3.13.8. Slot lighting detail

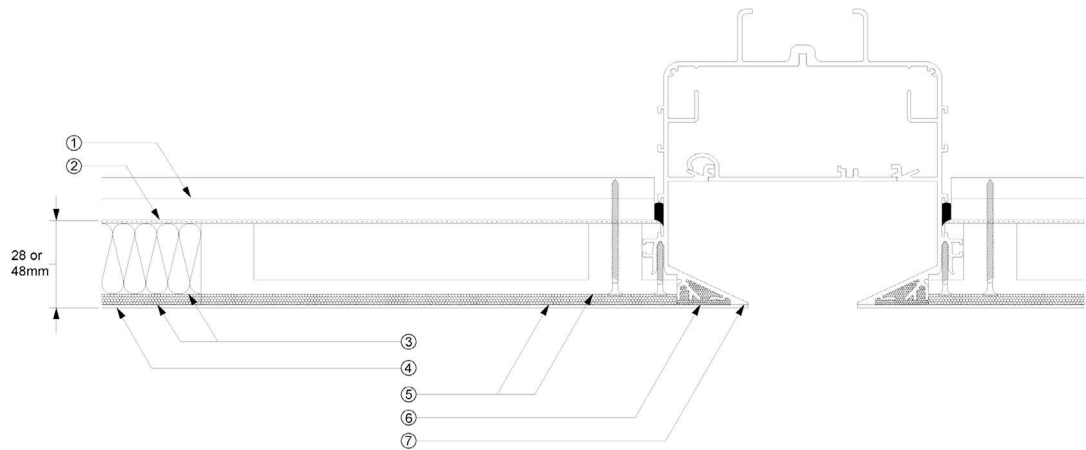

- 1 Plasterboard Substrate
- 2 Armourcoat Bondplast (0.5mm)
- 3 Armourcoat Precoated Board and Undercoat (5-7mm)
- 4 Armourcoat Acoustic Topcoat (2mm)
- 5 Armourcoat Slot Light Pattress
- 6 Armourcoat Acoustic Filler
- 7 Lighting Track

3.13.9. Trimless downlight detail

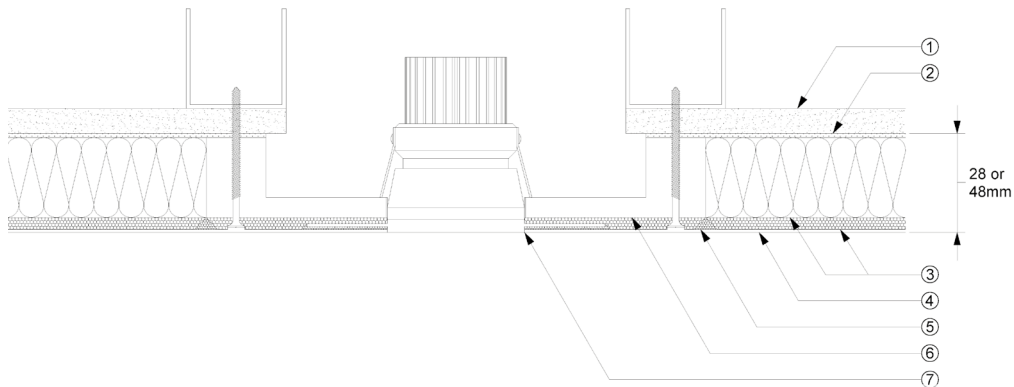

- 1 Plasterboard Substrate
- 2 Armourcoat Bondplast (0.5mm)
- 3 Armourcoat Precoated Mineral Wool Board
- 4 Armourcoat Acoustic Topcoat (2mm)
- 5 Armourcoat Joint Filler
- 6 Armourcoat Precoated Mounting Pad
- 7 Recessed Down Light

3.13.10. Access panel detail

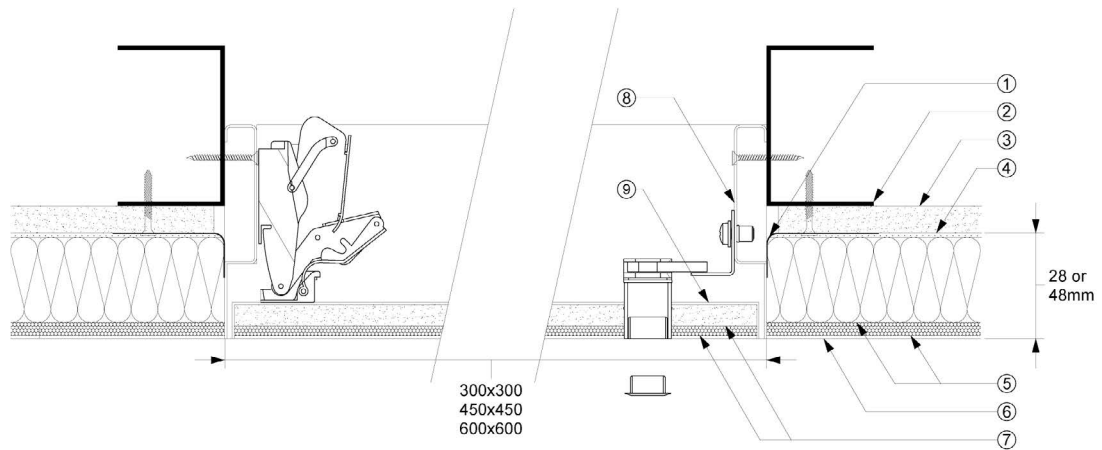

- 1 Airtight Tape
- 2 C Section Stud
- 3 Plasterboard Substrate
- 4 Armourcoat Bondplast
- 5 Armourcoat Precoated Board and Undercoat (5-7mm)
- 6 Armourcoat Acoustic Topcoat
- 7 10mm Fermacell board pre-coated with 5-6mm Acoustic Basecoat
- 8 Access Hatch Frame
- 9 Access Hatch Door

3.13.11. Cover up light detail

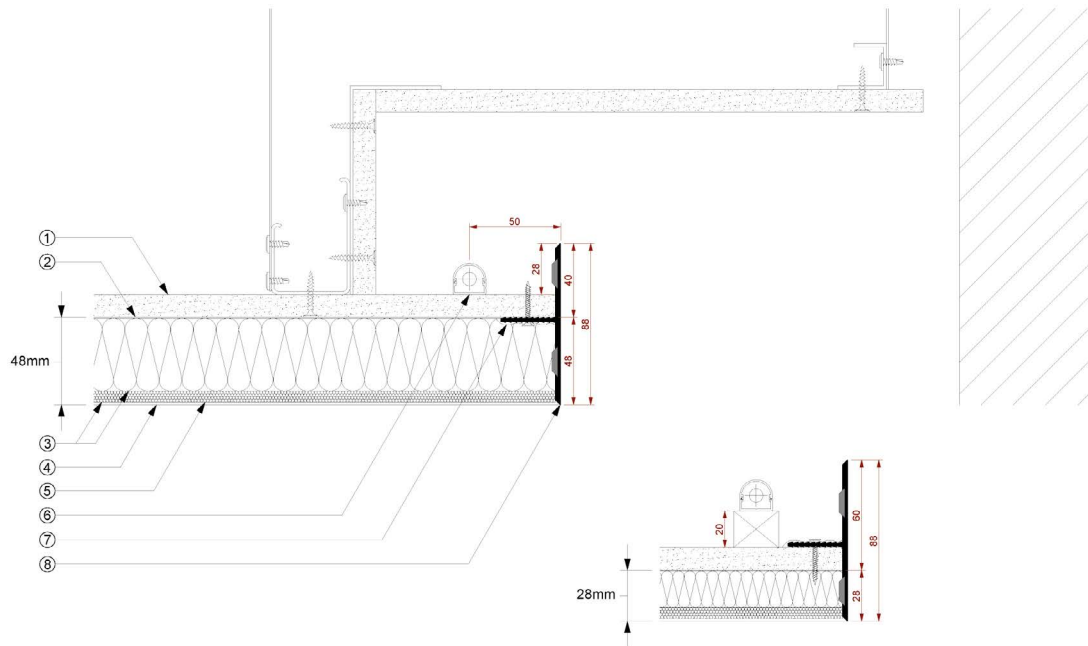

- 1 Plasterboard Substrate
- 2 Armourcoat Bondplast (0.5mm)
- 3 Armourcoat Precoated Board and Undercoat (5-7mm)
- 4 Armourcoat Acoustic Topcoat (2mm)
- 5 Armourcoat Acoustic Joint Filler
- 6 Trough Light - Hafele 833.74.814
- 7 Adhesive
- 8 Armourcoat Coving Trim

3.13.12. New coving detail

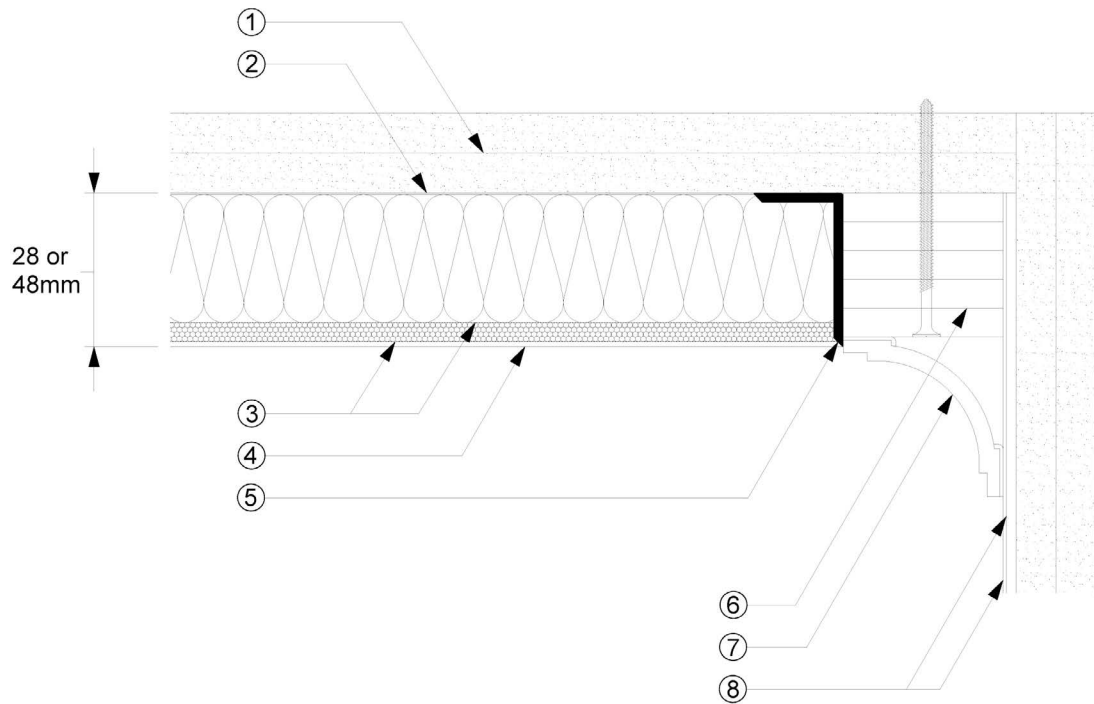

- 1 Plasterboard Substrate
- 2 Armourcoat Bondplast (0.5mm)
- 3 Armourcoat Precoated Board and Undercoat (5-7mm)
- 4 Armourcoat Acoustic Topcoat (2mm)
- 5 L section edge trim
- 6 Gypsum board for coving mount, installed by others prior to Armourcoat Acoustic
Note: Coving mount must be lower than proposed L section edge trim
- 7 Coving, design of interface and installation by others post the Acoustic application
- 8 Taped & Jointed or skimmed P/B, Sealed + 1mm PP Finish

3.13.13. Existing coving detail

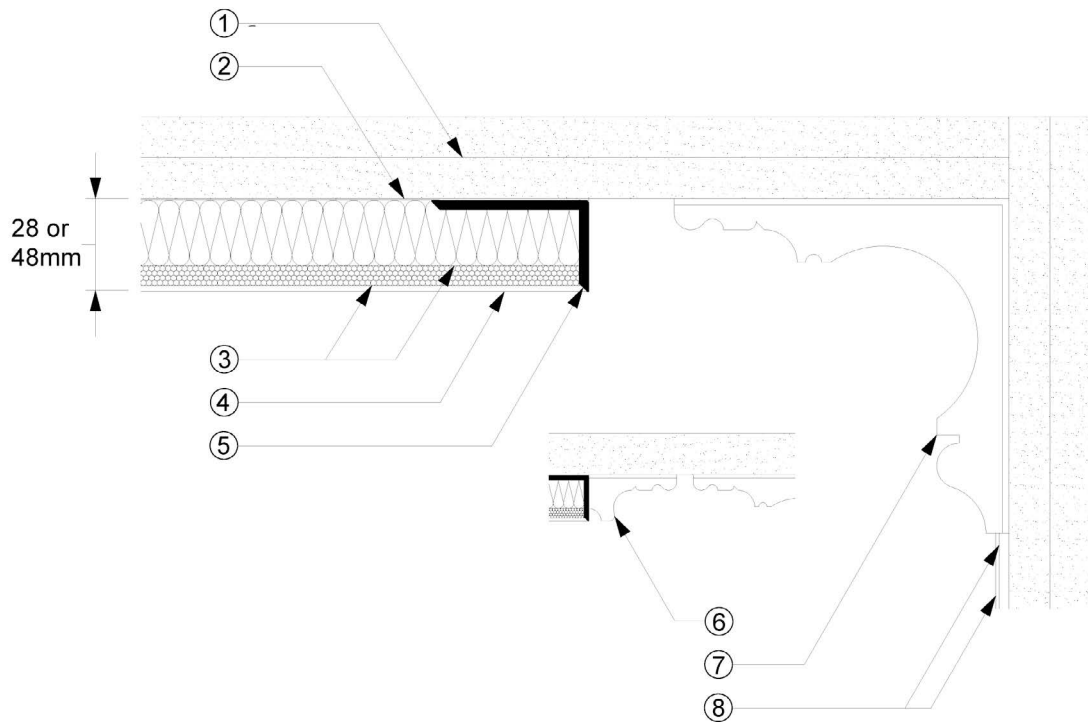

- 1 Plasterboard Substrate
- 2 Armourcoat Bondplast (0.5mm)
- 3 Armourcoat Precoated Board and Undercoat (5-7mm)
- 4 Armourcoat Acoustic Topcoat (2mm)
- 5 L Section edge trim
- 6 Optional custom coving interface profile
- 7 Existing Coving
- 8 Taped, Jointed & Sealed P/B + 1mm PP Finish

3.13.14. Heavy ceiling fittings

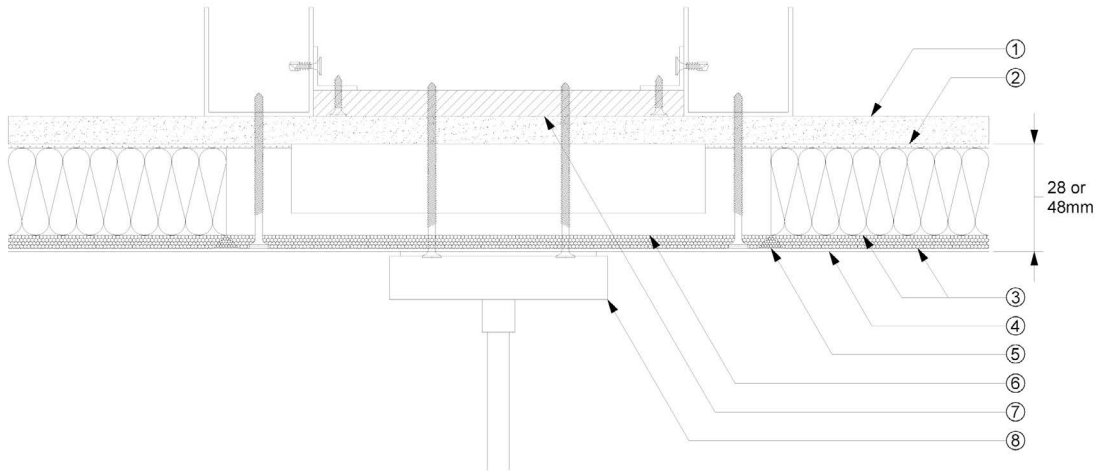

- 1 Plasterboard Substrate
- 2 Armourcoat Bondplast (0.5mm)
- 3 Armourcoat Precoated Board and Undercoat (5-7mm)
- 4 Armourcoat Acoustic Topcoat (2mm)
- 5 Armourcoat Acoustic Joint filler
- 6 Custom Gypsum Pattress Mounting Pad
- 7 Plywood to support light fitting - Design & Install by others
- 8 Heavy Fitting - Installed by others

4. CLEANING AND MAINTENANCE

Armourcoat Acoustic Plaster provides a natural mineral surface made primarily from finely bound grains of white marble. Whilst it is a resilient surface there is always a chance that over time it will be subject to damage or become soiled by airborne dust and dirt. We therefore offer a range of services to clean, repair or restore the surface finish.

4.1. DUST REMOVAL

Areas which are subject to greater air movement (near air conditioning vents, doors etc) are likely to gradually pick up a small amount of airborne dust. This is best removed using a vacuum cleaner with a fine brush attachment.

4.2. STAIN REMOVAL

Any organic stains can be removed easily by the application of either a mild bleach or Peroxide cleaner. Apply to the surface using a sponge or foam roller.

4.3. SCUFF AND SURFACE MARKS

Scuff marks and other dirty marks on the surface can often be easily removed using a white pencil eraser or an adhesive tape such as Sellotape.

4.4. DAMAGE REPAIR

Any repairs of damage to the surface should be undertaken by a specialist applicator that is familiar with using the material. It is possible to make minor repairs which are very well disguised but moving light fittings or access hatches will almost always result in a visible patch repair.

4.5. RESTORATION

There are circumstances where it is not possible to adequately repair or clean the surface fully due to age or the extent of the damage and it is therefore necessary to undertake a full restoration.

Fortunately it is possible to remove just the final topcoat plaster and reapply a new layer of Acoustic Topcoat without the need to remove and reinstate the base panels. This will provide a brand-new appearance without affecting the acoustical performance of the system.

5. WARRANTY

A five year limited materials warranty is supplied with the Armourcoat Acoustic Plaster System.